



## ST Submersible Pumps

---

Made in Taiwan



Catalogue 60 Hz

# 4" ST Submersible Pump



## Model code

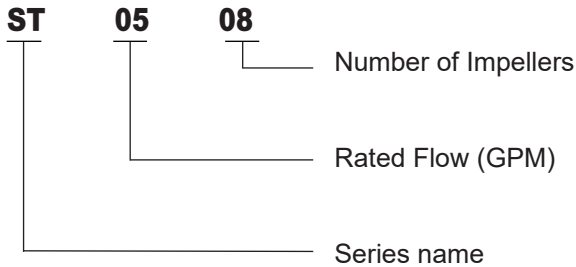

### APPLICATIONS

- Water Supply
- Irrigation
- Pressure Boosting

### GENERAL SPECIFICATIONS PUMP

- Delivery: up to 27.8 m<sup>3</sup>/h at 3450 rpm
- Head: up to 410 m at 3450 rpm
- Maximum permissible quantity of sand: 150g/m<sup>3</sup>
- ST05-ST07-ST10-ST13-ST18 models 1 ¼" discharge.
- ST25 model 1½" discharge.
- ST35-ST40-ST55-ST60-ST80 models 2" discharge.
- Motor Power: from 0.37 to 7.5 kW.

**Discharge Head and Motor Adaptor** are precision machined cast 304 stainless steel for superior strength and durability. The motor adaptor is NEMA standard.

**Impellers are floating type made with Noryl®** for a superior sand handling. Together with glass filled polycarbonate diffusers make the super strong pumps for maximum wear and abrasive resistance. The materials are FDA compliant materials.

**Impeller Bowls** are made from 304 stainless steel, maximizing wear from abrasion.

**Shaft Coupling** is made from 304 stainless steel for easy alignment to the motor shaft.

**Strainer** is made from stamped 304 stainless steel for rigidity.

**Non-Return valve** made from 304 stainless steel, fitted in the discharge to prevent any back flow of water and alleviate any water hammer to the pumps.

**Pump Shaft** is made from hex 304 stainless steel bar material for high corrosion resistance.

**Bearing** is made with Polyacetal for strong wear and abrasive resistance.

**Pump body** is covered by a 1.5mm thick 304 polished stainless steel casing, ensures optimum resistance to abrasion.

# Performance range

ST 4"

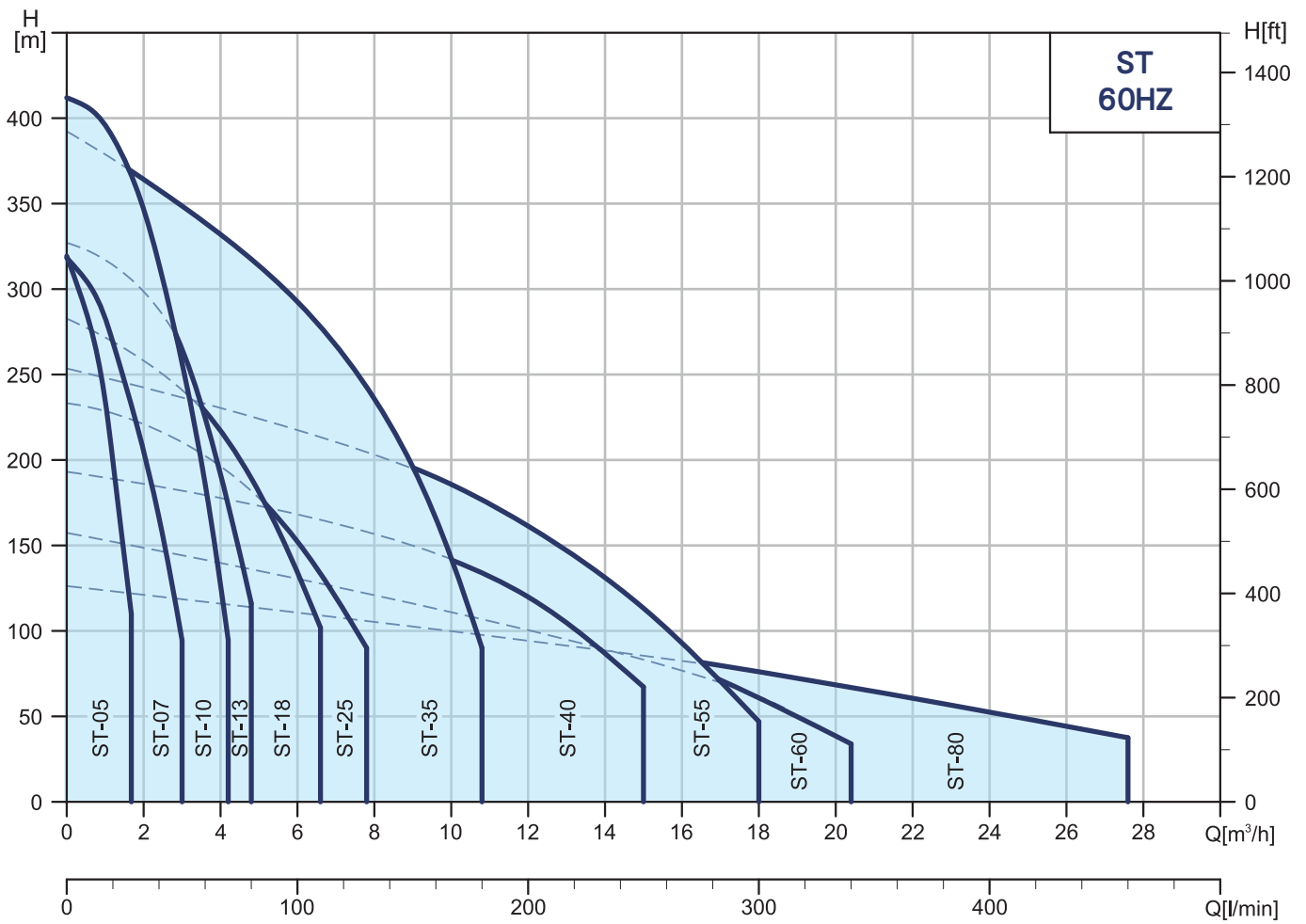

# Material Specification



ST 4"

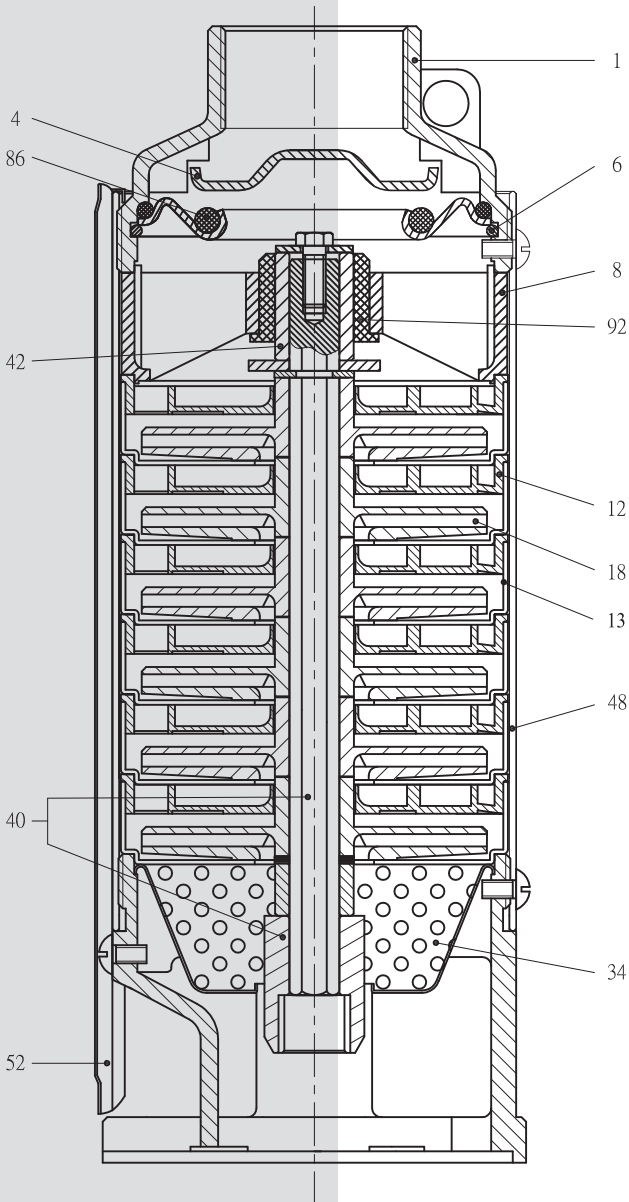

Pos.	Part Name	Material
1	Discharge Head	AISI 304 SS
4	Check Valve Cone	AISI 304 SS
6	Check Valve retaining Ring	AISI 304 SS
8	Bearing Spider	Glass Filled Polycarbonate
12	Diffuser	Glass Filled Polycarbonate
13	Bowl	AISI 304 SS
18	Impeller	Noryl
34	Strainer	AISI 304 SS
40	Pump Shaft / Coupling	AISI 304 SS
42	Shaft Sleeve	AISI 304 SS or Noryl
48	Pump Casing	AISI 304 SS
52	Cable Guard	AISI 304 SS
86	O-Ring	NBR
92	Bearing	Polyacetal

# Performance Curves

# ST-05

## ST 4"

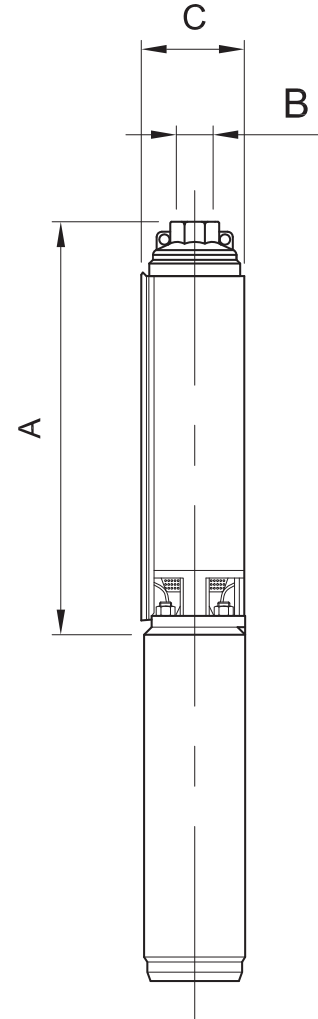
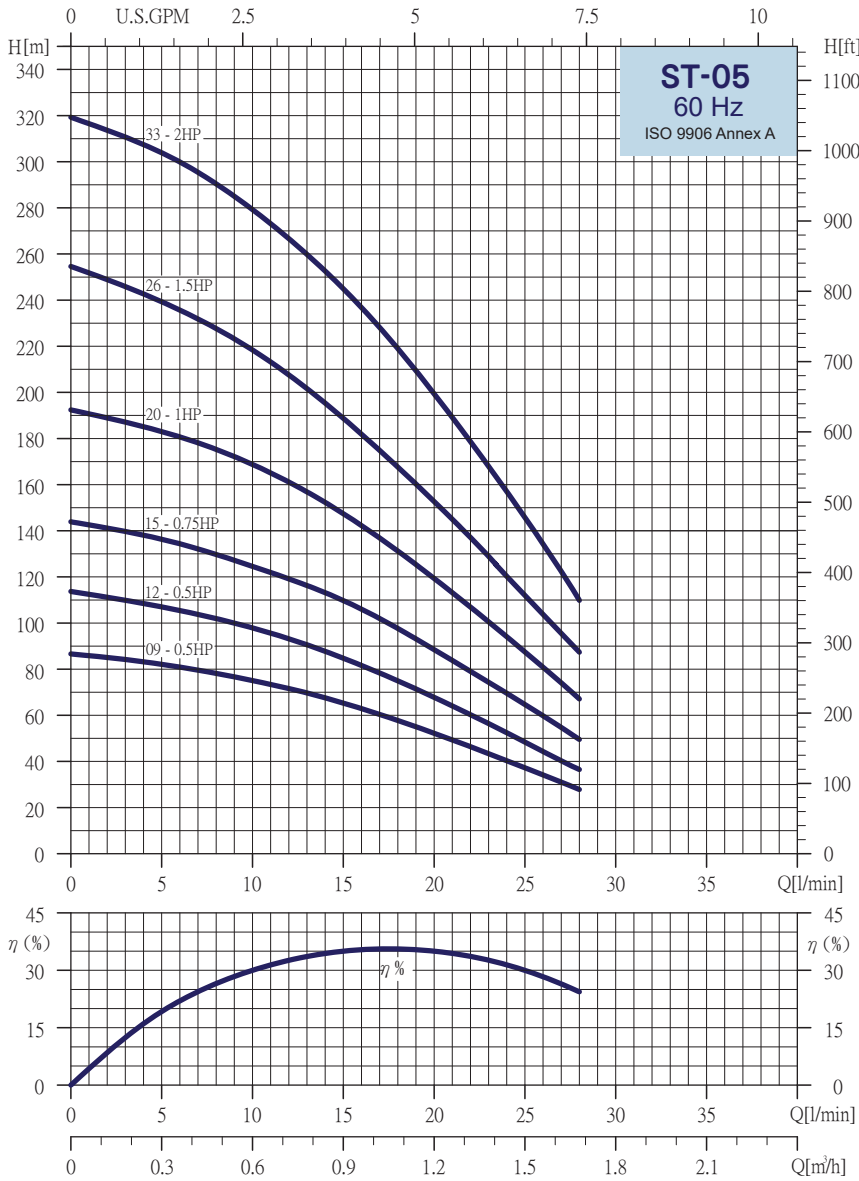

Selection Chart									
PUMP TYPE	STAGES	MOTOR		Q=DELIVERY					
				l/min 0	10	15	20	25	30
		KW	HP	m <sup>3</sup> /h 0	0.6	0.9	1.2	1.5	1.8
H=TOTAL HEAD IN METERS									
ST-0509	9	0.37	0.5	87	75	65	52	38	21
ST-0512	12	0.37	0.5	114	98	85	68	49	28
ST-0515	15	0.55	0.75	144	124	110	89	65	39
ST-0520	20	0.75	1.0	193	169	148	120	88	53
ST-0526	26	1.1	1.5	255	219	179	152	112	68
ST-0533	33	1.5	2.0	320	280	245	200	145	82

Dimensions and Weights				
Pump Type	Dimensions(mm)			N.W (kg)
	A	B	C	
ST-0509	306	RP : 1/4" NPT :	98	3.1
ST-0512	359		98	3.6
ST-0515	411		98	4.1
ST-0520	499		98	4.9
ST-0526	642		98	5.8
ST-0533	820		98	8.3

The ● means outer sleeve made by 2 pieces

# Performance Curves

ST 4"

# ST-07

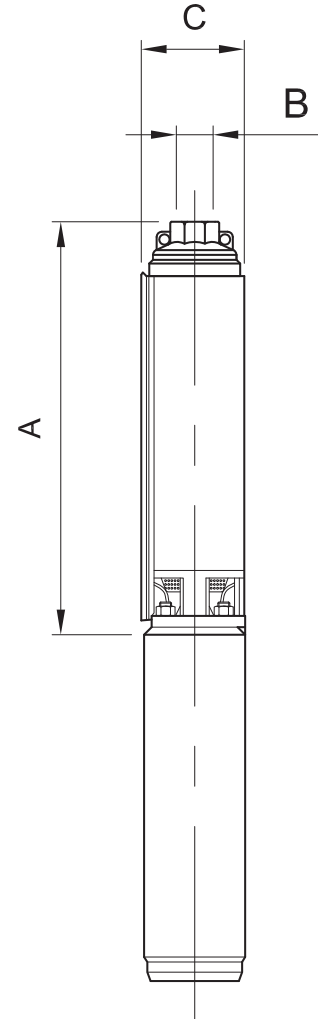
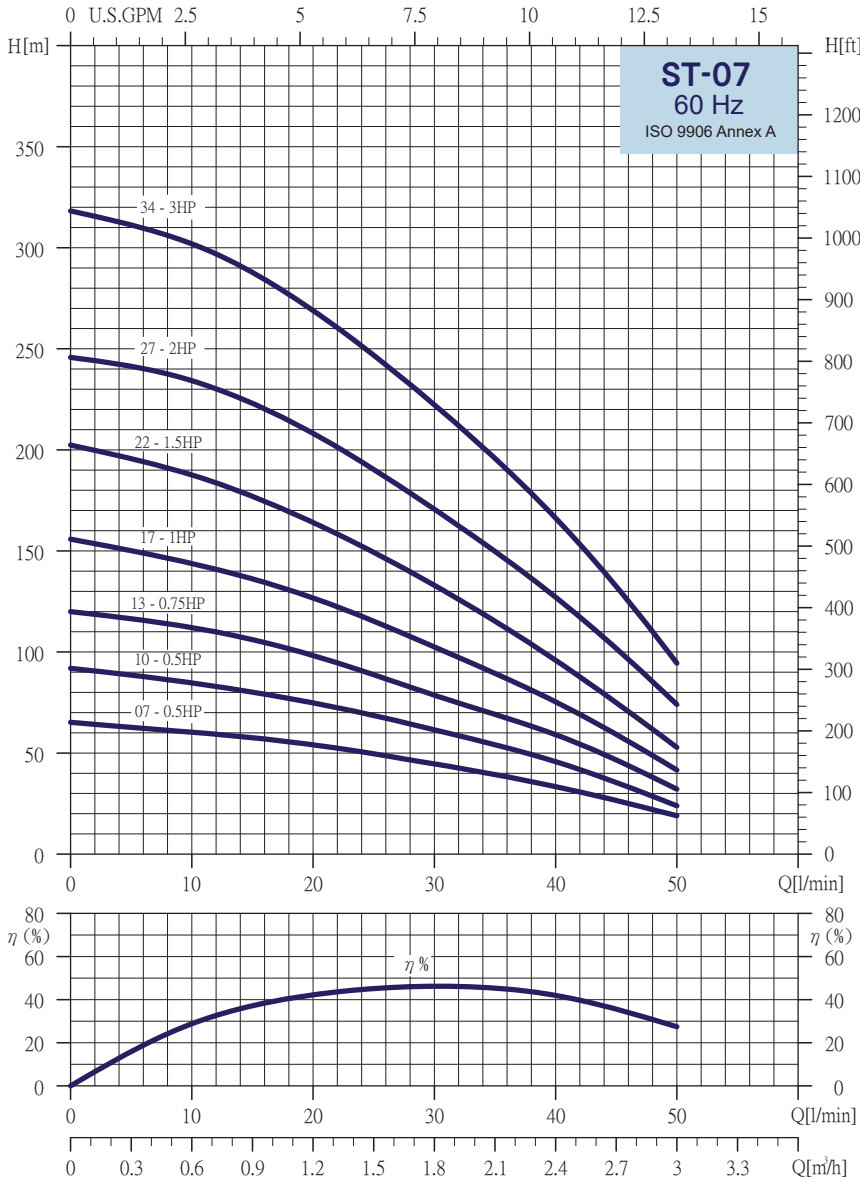

Selection Chart													
PUMP TYPE	STAGES	MOTOR		Q=DELIVERY									
				l/min	10	15	20	25	30	35	40	50	
		KW	HP	m <sup>3</sup> /h	0.6	0.9	1.2	1.5	1.8	2.1	2.4	3.0	
H=TOTAL HEAD IN METERS													
ST-0707	7	0.37	0.5	66		57	54	49	44	39	33	19	
ST-0710	10	0.37	0.5	92		80	75	68	62	54	47	24	
ST-0713	13	0.55	0.75	120		106	98	89	79	69	59	32	
ST-0717	17	0.75	1.0	156		136	127	115	102	89	75	42	
ST-0722	22	1.1	1.5	203		177	165	150	133	115	97	53	
ST-0727	27	1.5	2.0	246		223	208	190	171	150	127	74	
ST-0734	34	2.2	3.0	318		288	269	247	223	196	167	95	

Dimensions and Weights				
Pump Type	Dimensions(mm)			N.W (kg)
	A	B	C	
ST-0707	275	RP : 1/4" NPT :	98	2.7
ST-0710	330		98	3.3
ST-0713	385		98	3.8
ST-0717	455		98	4.5
ST-0722	545		98	5.4
ST-0727	675		98	6.6
ST-0734	858		98	9.3

● The ● means outer sleeve made by 2 pieces

# Performance Curves

ST 4"

# ST-10

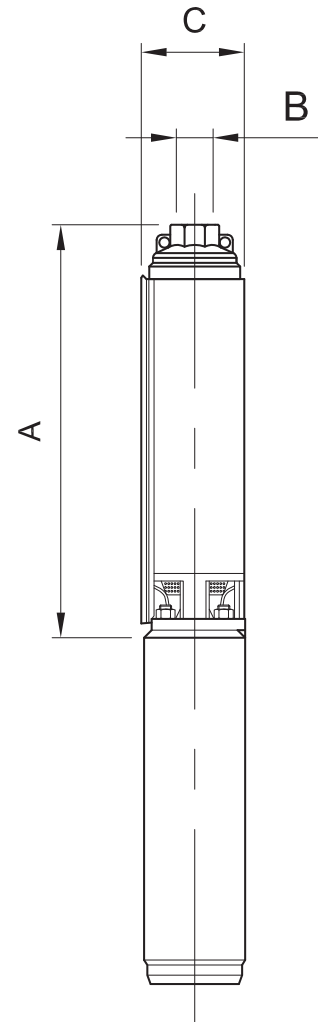
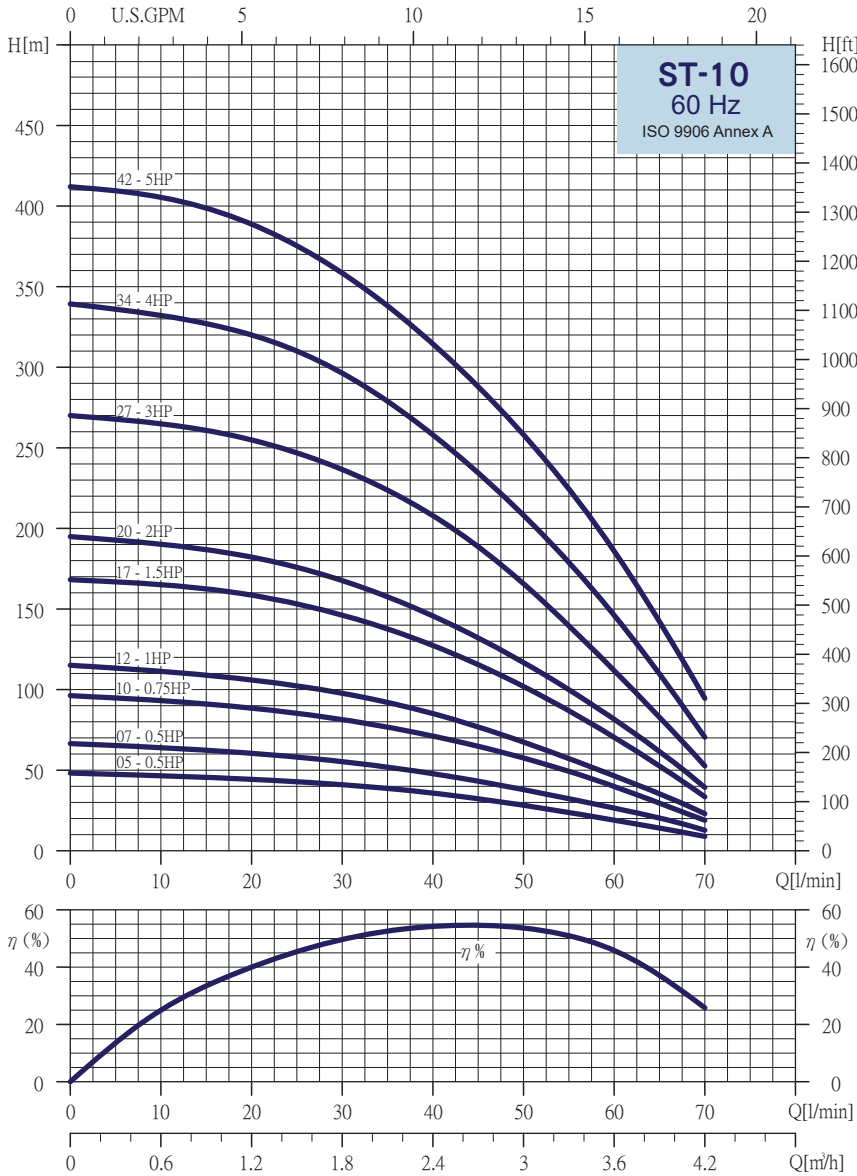

Selection Chart													
PUMP TYPE	STAGES	MOTOR		Q=DELIVERY									
				l/min	0	15	20	25	30	35	40	50	60
		KW	HP	m³/h	0	0.9	1.2	1.5	1.8	2.1	2.4	3.0	3.6
H=TOTAL HEAD IN METERS													
ST-1005	5	0.37	0.5	48		44	42	40	38	36	29	19	9
ST-1007	7	0.37	0.5	67		60	58	55	52	49	39	27	13
ST-1010	10	0.55	0.75	96		89	85	81	77	71	58	40	19
ST-1012	12	0.75	1.0	115		106	102	98	92	85	68	47	23
ST-1017	17	1.1	1.5	168		159	152	147	138	128	102	70	35
ST-1020	20	1.5	2.0	195		181	177	168	158	146	118	82	40
ST-1027	27	2.2	3.0	270		255	247	237	223	209	167	111	53
● ST-1034	34	3.0	4.0	339		320	310	296	280	259	209	146	70
● ST-1042	42	3.7	5.0	412		389	375	358	338	315	258	186	95

Dimensions and Weights				
Pump Type	Dimensions(mm)			N.W (kg)
	A	B	C	
ST-1005	236	RP : 1 1/4"	98	2.5
ST-1007	271		98	2.8
ST-1010	324		98	3.3
ST-1012	359		98	3.6
ST-1017	447		98	4.4
ST-1020	499		98	4.9
ST-1027	660		98	6.0
ST-1034	840		98	8.5
ST-1042	980		98	9.8

The ● means outer sleeve made by 2 pieces

# Performance Curves

ST 4"

# ST-13

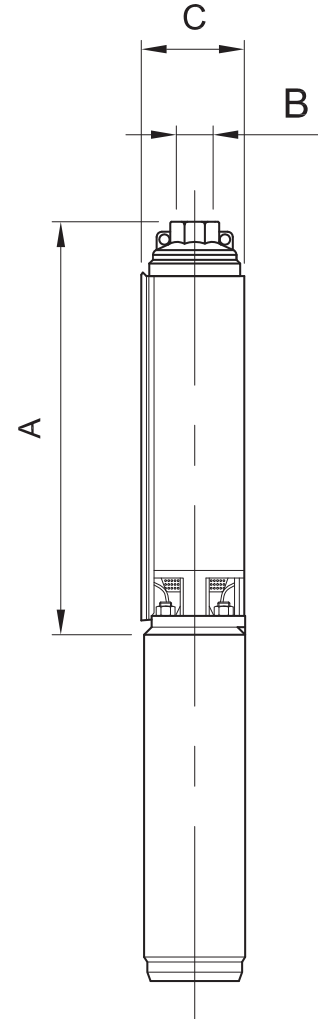
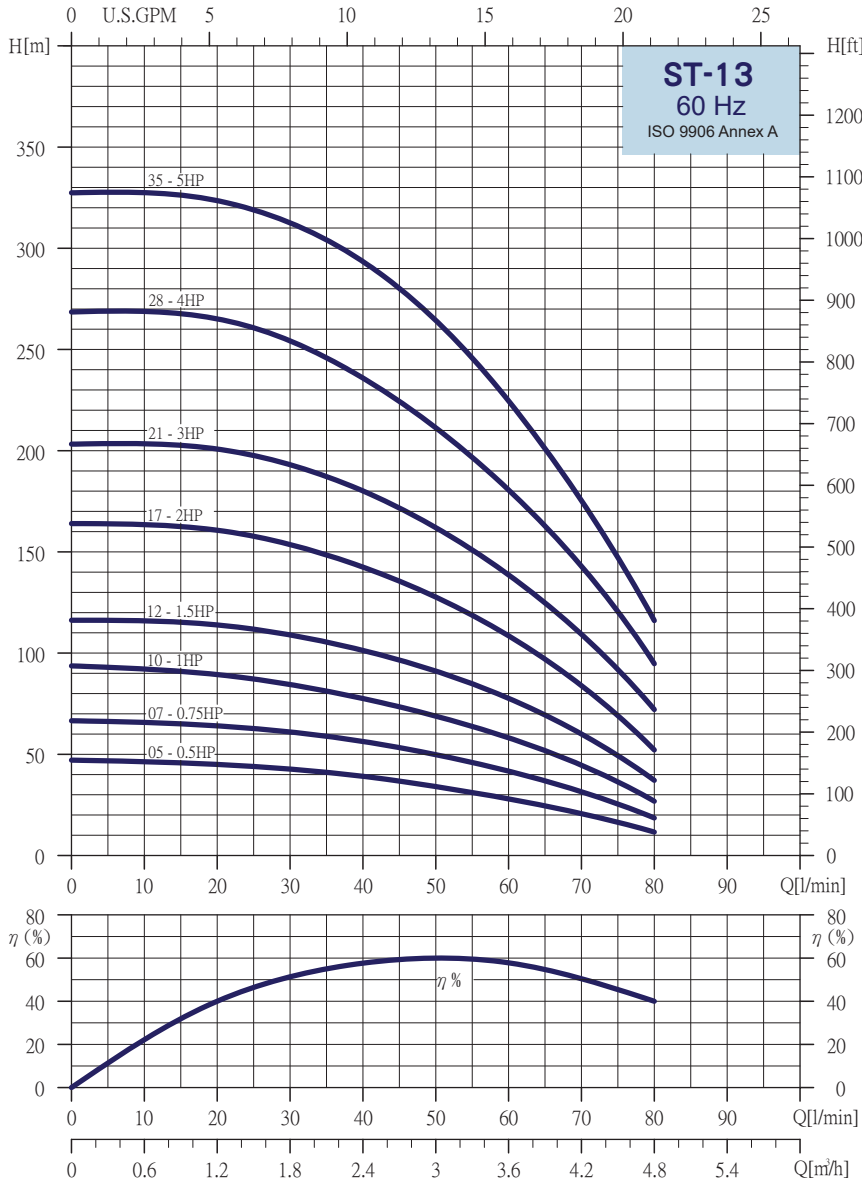

Selection Chart													
PUMP TYPE	STAGES	MOTOR		Q=DELIVERY									
				l/min	25	30	35	40	50	60	70	80	
		KW	HP	m³/h	1.5	1.8	2.1	2.4	3.0	3.6	4.2	4.8	
H=TOTAL HEAD IN METERS													
ST-1305	5	0.37	0.5	47		42	40	39	34	28	21	12	
ST-1307	7	0.55	0.75	67		61	59	57	50	41	31	19	
ST-1310	10	0.75	1.0	94		85	81	78	69	58	45	28	
ST-1312	12	1.1	1.5	116		109	106	102	91	78	60	38	
ST-1317	17	1.5	2.0	165		154	148	143	128	109	83	53	
ST-1321	21	2.2	3.0	204		193	187	180	162	139	110	72	
ST-1328	28	3.0	4.0	269		254	246	236	211	180	142	96	
ST-1335	35	3.7	5.0	327		312	304	292	264	223	175	117	

Dimensions and Weights				
Pump Type	Dimensions(mm)			N.W (kg)
	A	B	C	
ST-1305	236	RP : 1/4" NPT:	98	2.5
ST-1307	271		98	2.8
ST-1310	324		98	3.2
ST-1312	359		98	3.5
ST-1317	447		98	4.3
ST-1321	519		98	5
ST-1328	679		98	6
ST-1335	857		98	8.6

The ● means outer sleeve made by 2 pieces



# Performance Curves

ST 4"

# ST-18

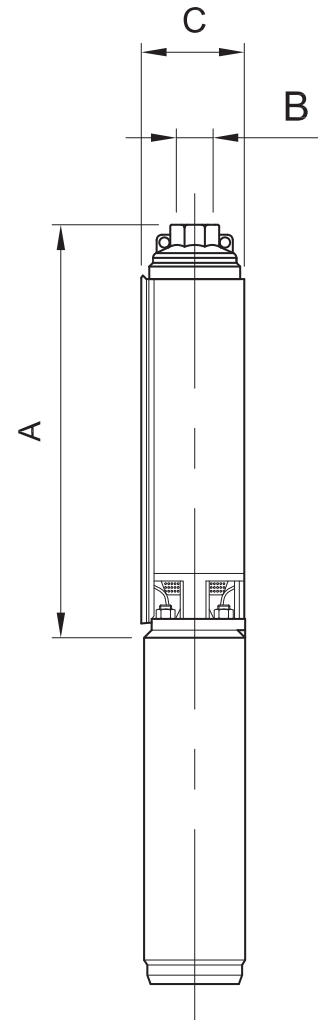
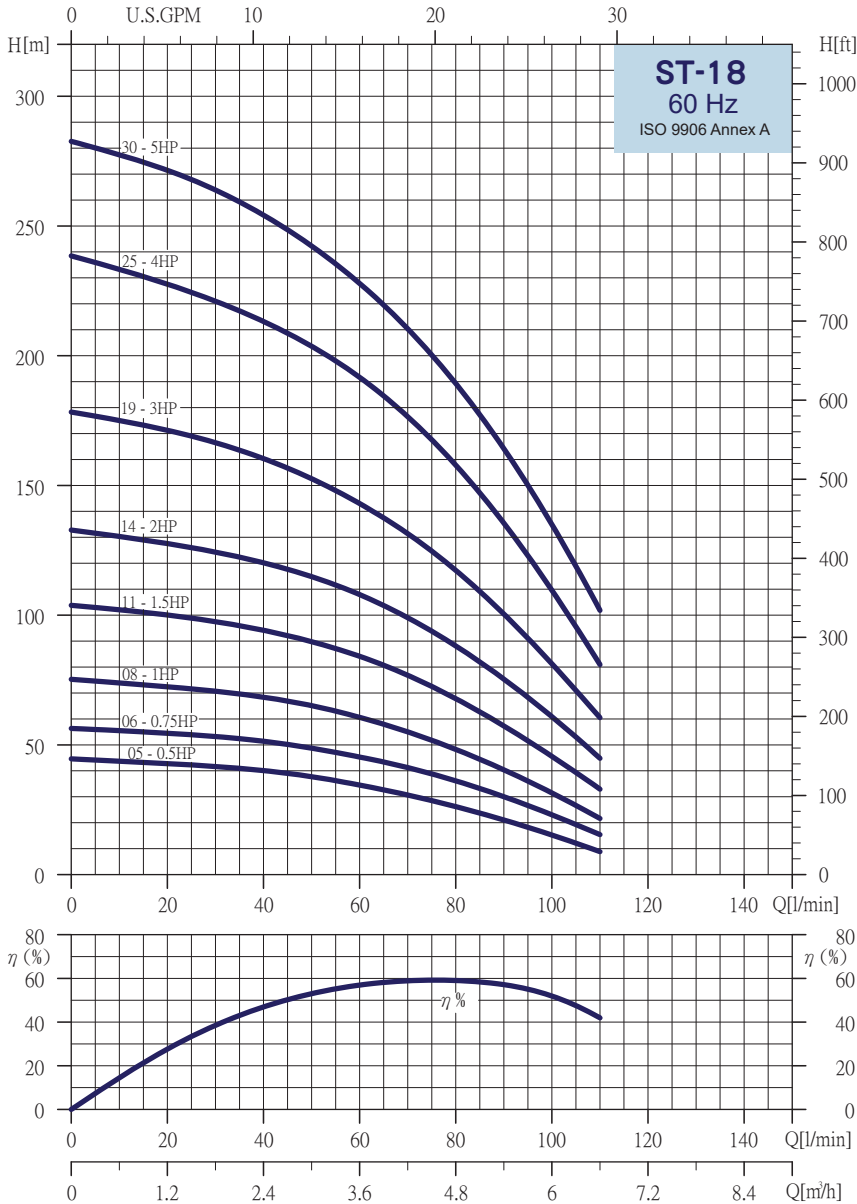

Selection Chart														
PUMP TYPE	STAGES	MOTOR		Q=DELIVERY										
				l/min	30	35	40	50	60	70	80	90	100	110
		KW	HP	m³/h	1.8	2.1	2.4	3.0	3.6	4.2	4.8	5.4	6.0	6.6
H=TOTAL HEAD IN METERS														
ST-1805	5	0.37	0.5	45		41	40	38	35	31	27	21	15	9
ST-1806	6	0.55	0.75	56		53	52	49	45	41	37	30	23	16
ST-1808	8	0.75	1.0	75		70	68	65	61	55	49	41	32	22
ST-1811	11	1.1	1.5	104		96	94	90	84	77	68	58	46	33
ST-1814	14	1.5	2.0	133		123	120	115	108	99	88	75	61	45
ST-1819	19	2.2	3.0	178		164	160	153	143	131	117	100	81	61
ST-1825	25	3.0	4.0	238		217	213	204	192	176	158	136	110	81
ST-1830	30	3.7	5.0	283		260	254	242	228	210	189	164	135	102

Dimensions and Weights				
Pump Type	Dimensions(mm)			N.W (kg)
	A	B	C	
ST-1805	257	RP : 1/4" NPT :	98	2.7
ST-1806	279		98	2.8
ST-1808	322		98	3.1
ST-1811	387		98	3.6
ST-1814	452		98	4.1
ST-1819	560		98	4.9
ST-1825	763		98	6.9
ST-1830	885		98	8.1

The ● means outer sleeve made by 2 pieces

# Performance Curves

ST 4"

# ST-25

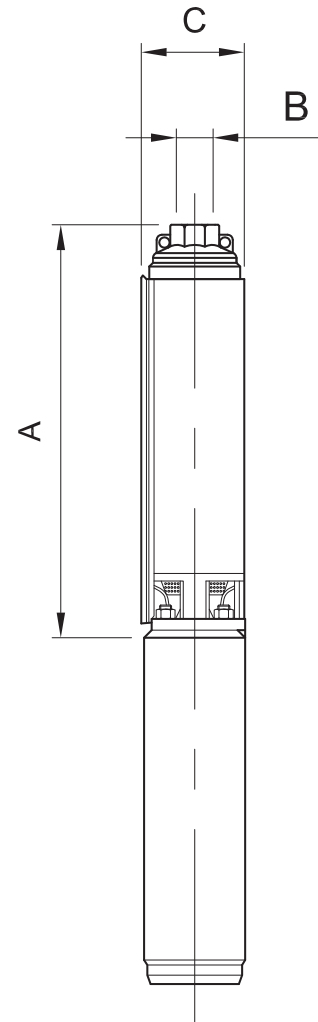
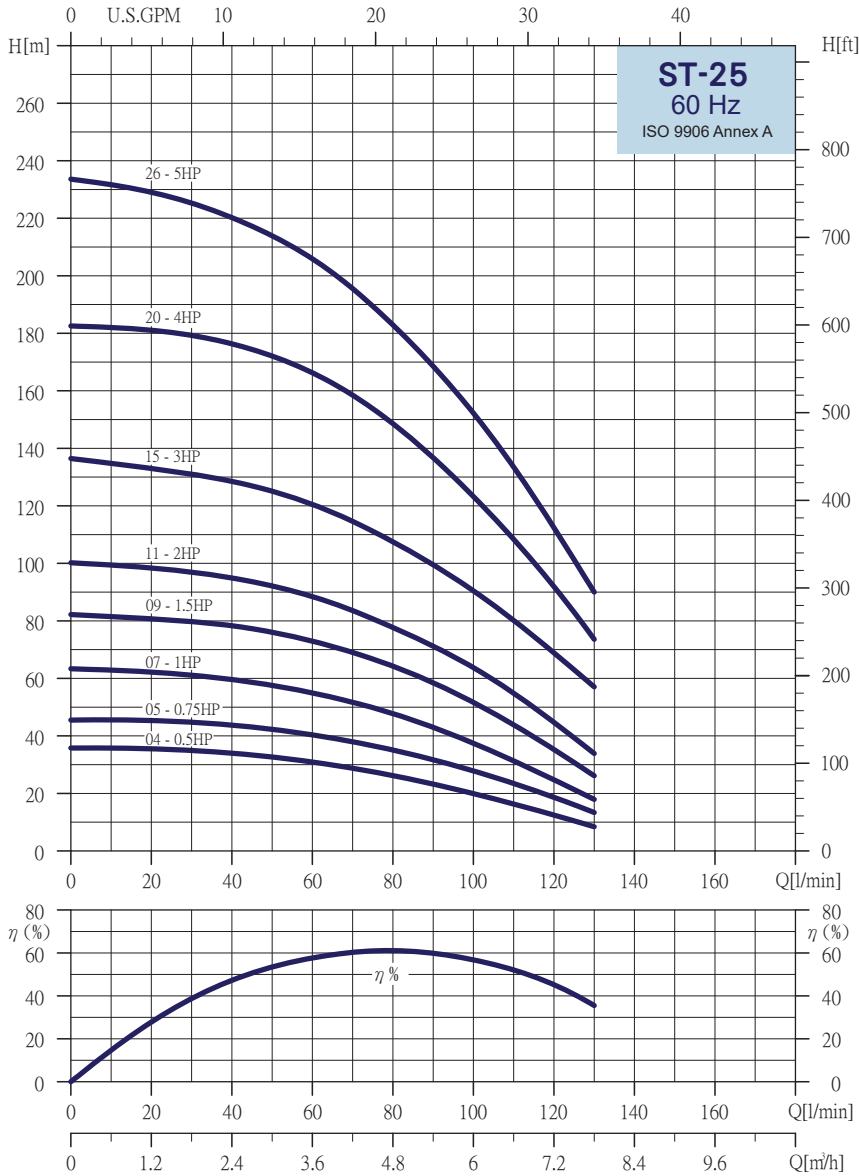

Selection Chart												
PUMP TYPE	STAGES	MOTOR		Q=DELIVERY								
				l/min	40	50	60	70	80	90	100	120
		KW	HP	m³/h	2.4	3.0	3.6	4.2	4.8	5.4	6.0	7.2
H=TOTAL HEAD IN METERS												
ST-2504	4	0.37	0.5	36		33	31	29	27	23	20	12
ST-2505	5	0.55	0.75	46		42	40	38	35	32	28	19
ST-2507	7	0.75	1.0	63		58	55	52	48	43	37	25
ST-2509	9	1.1	1.5	82		76	73	69	64	58	52	35
ST-2511	11	1.5	2.0	100		92	88	84	78	71	64	45
ST-2515	15	2.2	3.0	136		125	121	115	107	100	90	69
ST-2520	20	3	4.0	183		172	166	158	148	137	122	92
ST-2526	26	3.7	5.0	234		214	206	196	183	169	152	112

Dimensions and Weights				
Pump Type	Dimensions(mm)			N.W (kg)
	A	B	C	
ST-2504	247	RP : 1 1/2" NPT	98	2.4
ST-2505	272		98	2.6
ST-2507	320		98	3.1
ST-2509	370		98	3.5
ST-2511	419		98	3.9
ST-2515	518		98	4.7
ST-2520	679		98	5.8
ST-2526	864		98	8.1

# Performance Curves

ST 4"

# ST-35

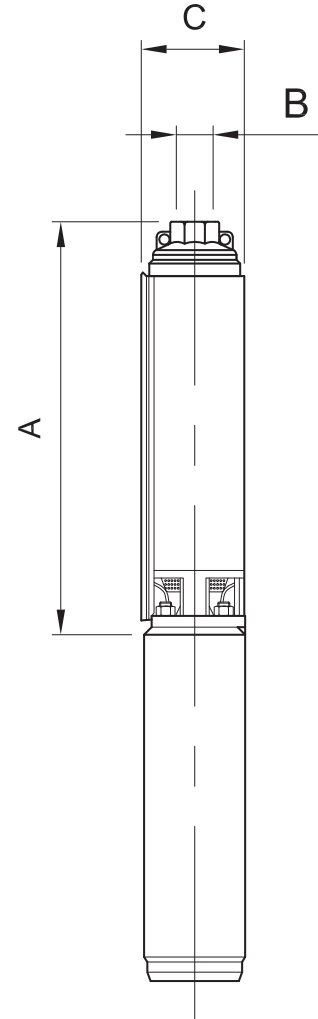
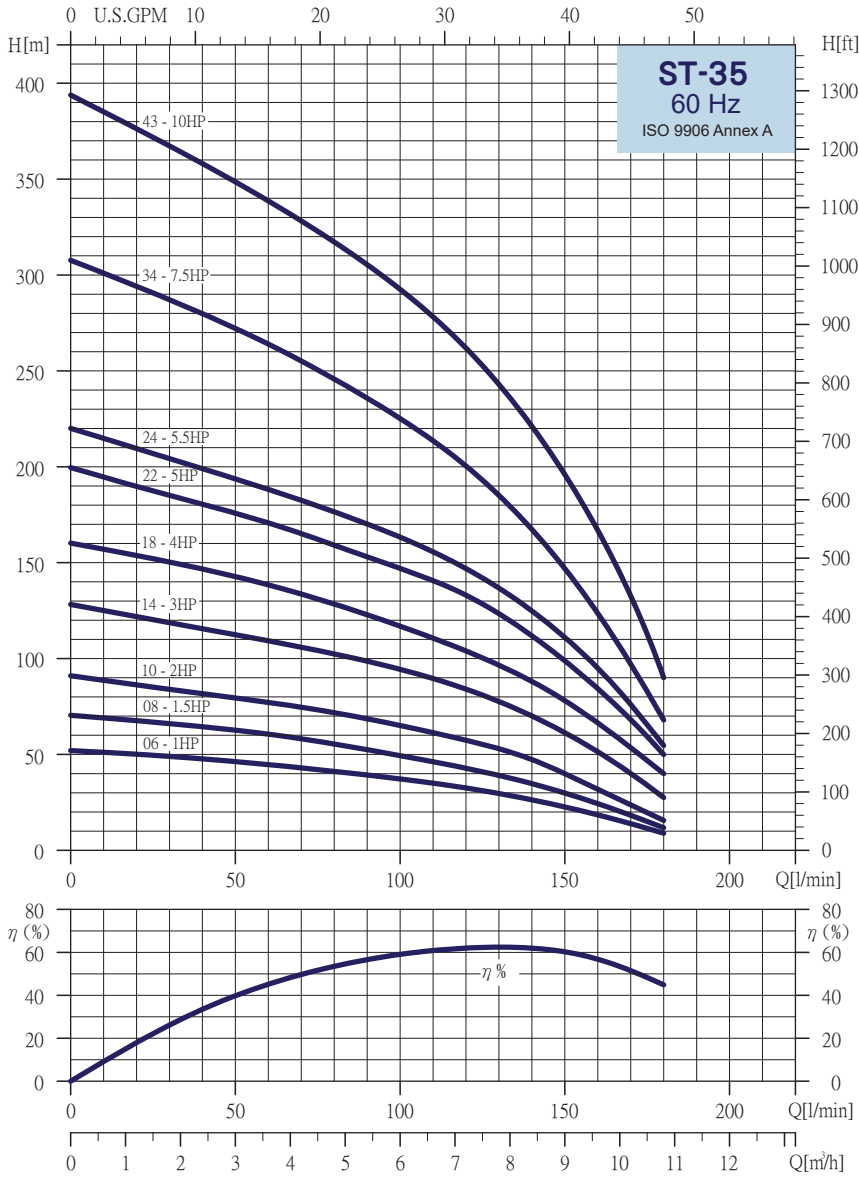

Selection Chart

PUMP TYPE	STAGES	MOTOR		Q=DELIVERY											
				H=TOTAL HEAD IN METERS											
		KW	HP	l/min 0	50	60	70	80	90	100	120	140	160	180	
				m³/h 0	3.0	3.6	4.2	4.8	5.4	6.0	7.2	8.4	9.6	10.8	
ST-3506	6	0.75	1	52		44	43	42	40	38	33	27	18	9	
ST-3508	8	1.1	1.5	70		60	58	55	52	50	43	35	24	12	
ST-3510	10	1.5	2.00	91		77	75	72	69	65	58	48	32	17	
ST-3514	14	2.2	3.00	128		109	106	102	99	94	83	70	51	29	
ST-3518	18	3.0	4.0	160		139	133	129	123	117	104	89	67	40	
ST-3522	22	3.7	5.0	200		170	165	159	152	147	132	111	84	50	
ST-3524	24	4.0	5.5	220		189	182	177	170	162	148	125	95	55	
● ST-3534	34	5.5	7.5	308		263	255	246	236	225	200	167	122	69	
● ST-3543	43	7.5	10	394		339	328	317	305	292	261	220	167	90	

The ● means outer sleeve made by 2 pieces

Dimensions and Weights

Pump Type	Dimensions(mm)			N.W (kg)
	A	B	C	
	PUMP			
ST-3506	359	RP : 2" NPT : 2"	98	3.4
ST-3508	421		98	4.0
ST-3510	483		98	4.6
ST-3514	607		98	5.7
ST-3518	731		98	6.9
ST-3522	893		98	8.1
ST-3524	993		98	9.7
ST-3534	1325		98	12.6
ST-3543	1676		98	15.2

# Performance Curves

ST 4"

# ST-40

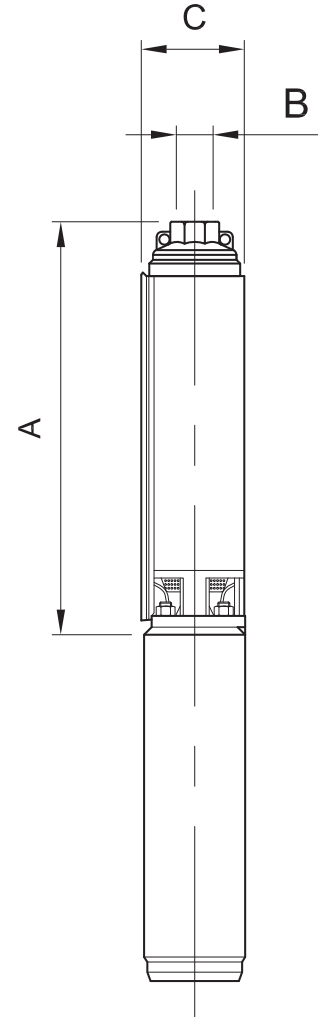
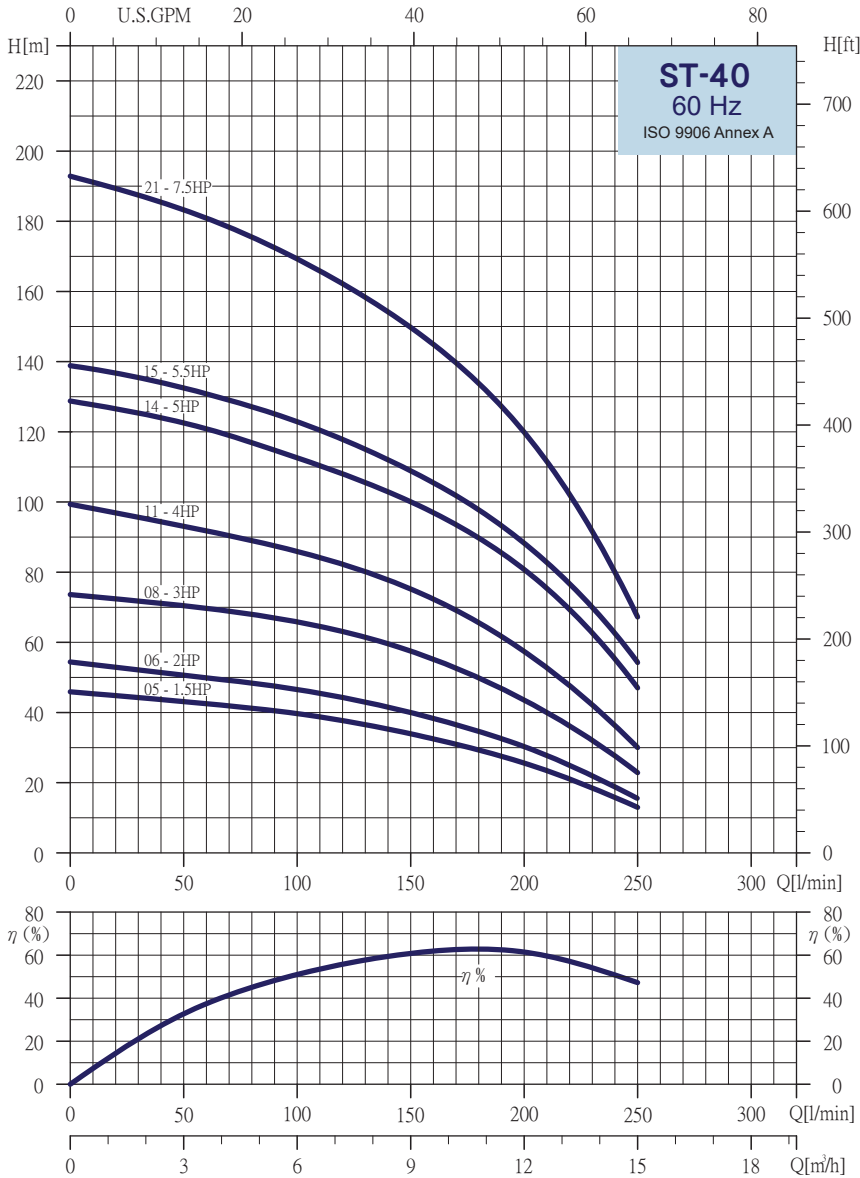

		Selection Chart													
PUMP TYPE	STAGES	MOTOR		Q=DELIVERY											
				l/min	60	70	80	90	100	120	140	160	180	200	250
		KW	HP	m <sup>3</sup> /h	3.6	4.2	4.8	5.4	6.0	7.2	8.4	9.6	10.8	12	15
H=TOTAL HEAD IN METERS															
ST-4005	5	1.1	1.5	46		42	41	40	39	37	35	33	29	25	14
ST-4006	6	1.5	2.0	55		49	48	47	47	45	42	38	35	30	17
ST-4008	8	2.2	3.0	74		69	68	67	66	63	60	56	50	43	24
ST-4011	11	3.0	4.0	100		91	88	87	86	83	78	73	66	58	30
ST-4014	14	3.7	5.0	129		118	116	115	113	108	103	97	90	81	48
ST-4015	15	4.0	5.5	139		128	126	125	123	118	113	105	97	88	55
ST-4021	21	5.5	7.5	194		178	175	173	169	162	154	145	134	120	68

Dimensions and Weights				
Pump Type	Dimensions(mm)			N.W (kg)
	A	B	C	
ST-4005	325	RP : 2" NPT : 2"	98	3.1
ST-4006	356		98	3.4
ST-4008	418		98	4.0
ST-4011	511		98	4.9
ST-4014	604		98	5.7
ST-4015	638		98	6.0
ST-4021	859		98	7.8

# Performance Curves

ST 4"

# ST-55

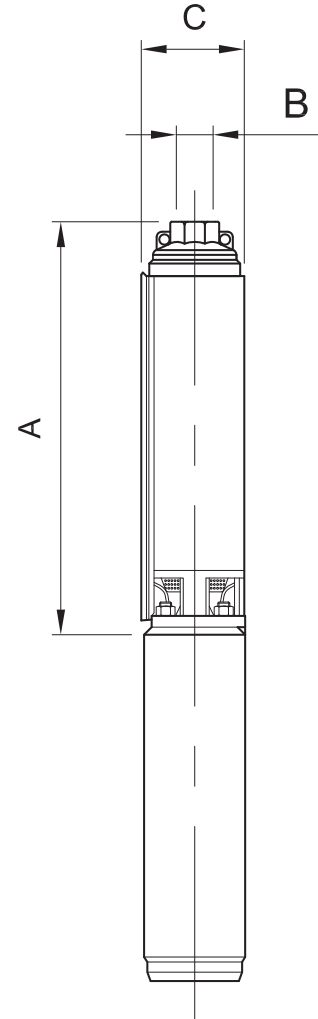
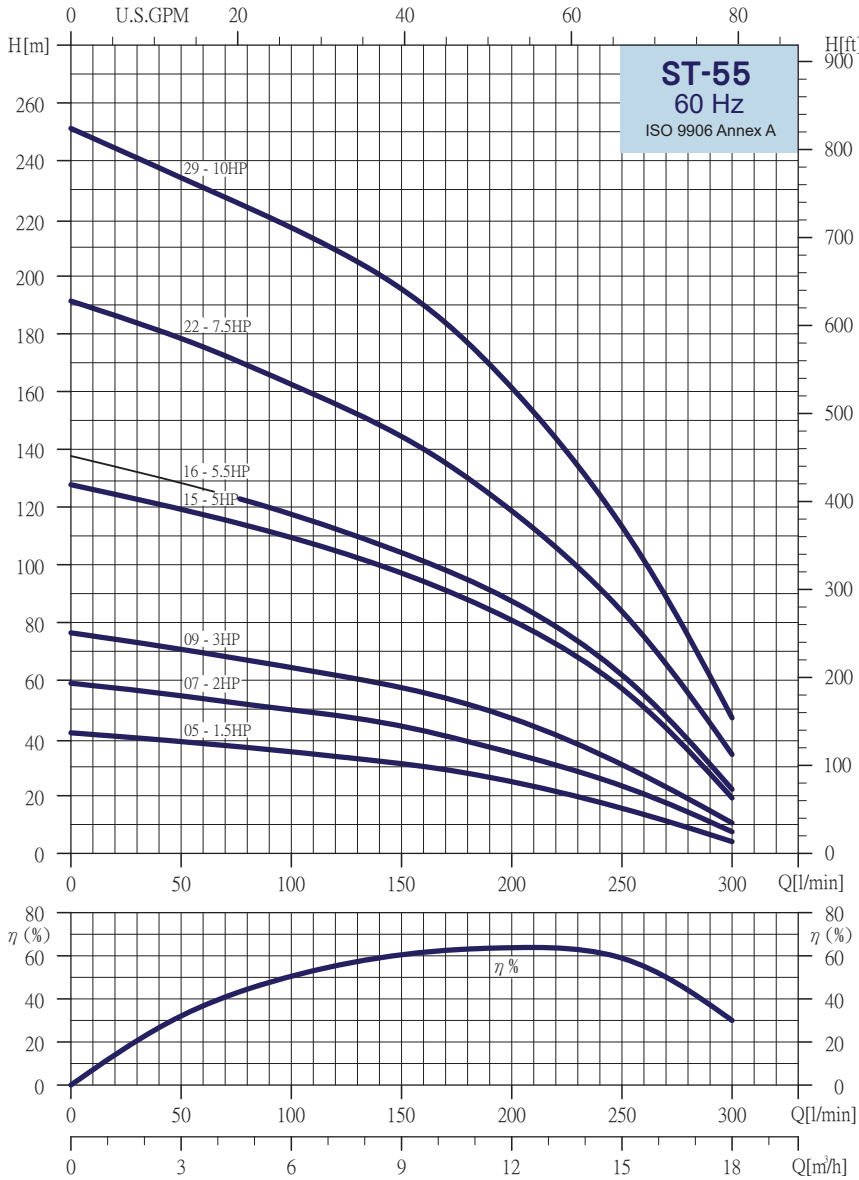

		Selection Chart																
PUMP TYPE	STAGES	MOTOR		Q=DELIVERY														
				l/min	70	80	90	100	120	140	160	180	200	220	240	260	280	300
		KW	HP	m³/h	4.2	4.8	5.4	6.0	7.2	8.4	9.6	10.8	12	13.2	14.4	15.6	16.8	18
				H=TOTAL HEAD IN METERS														
ST-5505	5	1.1	1.5	42		38	37	36	34	32	30	28	25	22	18	14	9	5
ST-5507	7	1.5	2.0	59		52	51	50	48	46	43	40	36	31	26	21	15	8
ST-5509	9	2	3.0	76		67	66	64	62	59	56	52	47	42	35	28	19	11
ST-5515	15	3.7	5.0	128		113	112	109	105	100	94	88	80	72	63	51	37	20
ST-5516	16	4.0	5.5	137		122	120	117	112	107	101	95	88	79	68	55	40	23
ST-5522	22	5.5	7.5	191		169	166	162	156	149	140	131	118	106	91	75	55	35
ST-5529	29	7.5	10	251		225	221	218	209	200	190	177	161	144	125	101	75	48

Dimensions and Weights				
Pump Type	Dimensions(mm)			N.W (kg)
	A	B	C	
ST-5505	433	RP : 2" NPT	98	4.3
ST-5507	537		98	5.3
ST-5509	641		98	6.2
ST-5515	953		98	9.0
ST-5516	1005		98	9.5
ST-5522	1410		98	13.3
ST-5529	1775		98	16.6

The ● means outer sleeve made by 2 pieces

# Performance Curves

ST 4"

# ST-60

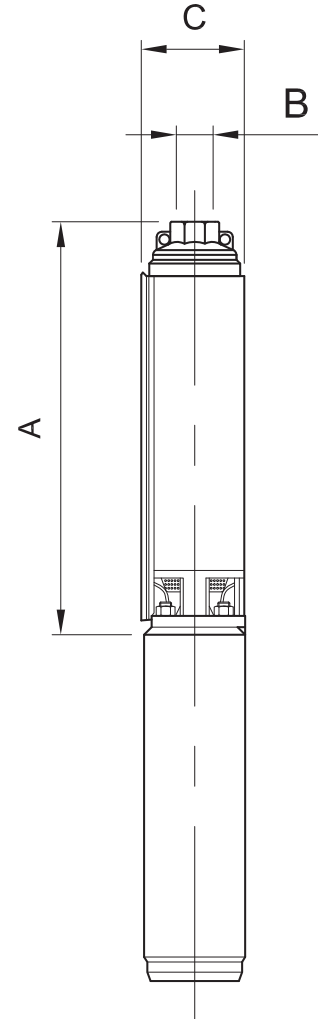
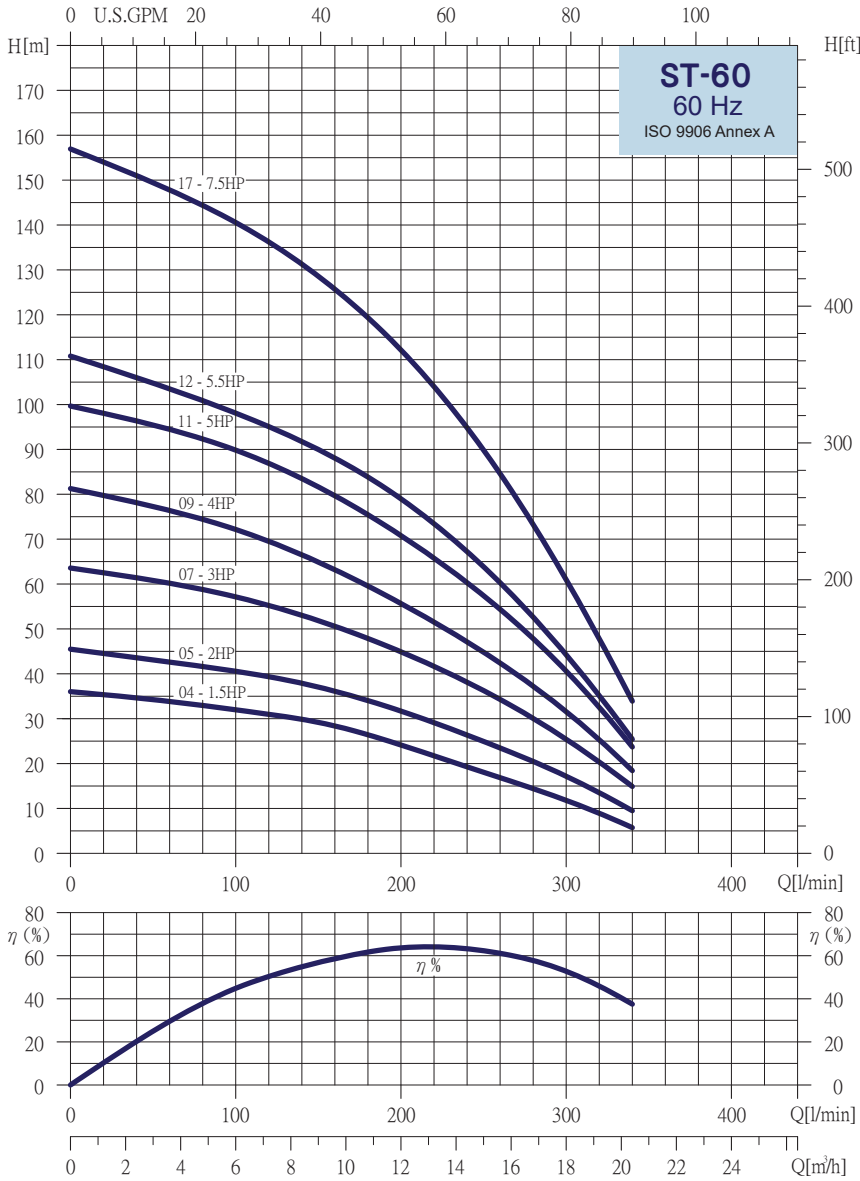

Selection Chart																	
PUMP TYPE	STAGES	MOTOR		Q=DELIVERY													
		KW	HP	H=TOTAL HEAD IN METERS													
				l/min	90	100	120	140	160	180	200	220	240	260	280	300	340
		m³/h	0	5.4	6.0	7.2	8.4	9.6	10.8	12	13.2	14.4	15.6	16.8	18	20.4	
ST-6004	4	1.1	1.5	36		32	31	30	28	26	24	22	19	17	14	12	6
ST-6005	5	1.5	2.0	46		41	39	37	36	34	32	29	26	23	20	17	9
ST-6007	7	2.2	3.0	64		57	55	53	51	48	45	42	38	34	30	25	15
ST-6009	9	3.0	4.0	82		72	69	67	64	60	56	52	47	42	37	32	18
ST-6011	11	3.7	5.0	100		90	87	83	80	75	71	67	60	54	48	41	24
ST-6012	12	4.0	5.5	110		98	95	92	88	84	78	73	67	60	55	44	26
ST-6017	17	5.5	7.5	157		140	136	131	126	119	112	104	95	85	73	61	35

Dimensions and Weights				
Pump Type	Dimensions(mm)			N.W (kg)
	A	B	C	
ST-6004	378	RP : 2" NPT :	98	3.9
ST-6005	430		98	4.4
ST-6007	534		98	5.3
ST-6009	638		98	6.3
ST-6011	742		98	7.2
ST-6012	797		98	7.7
ST-6017	1092		98	10.1

# Performance Curves

ST 4"

# ST-80

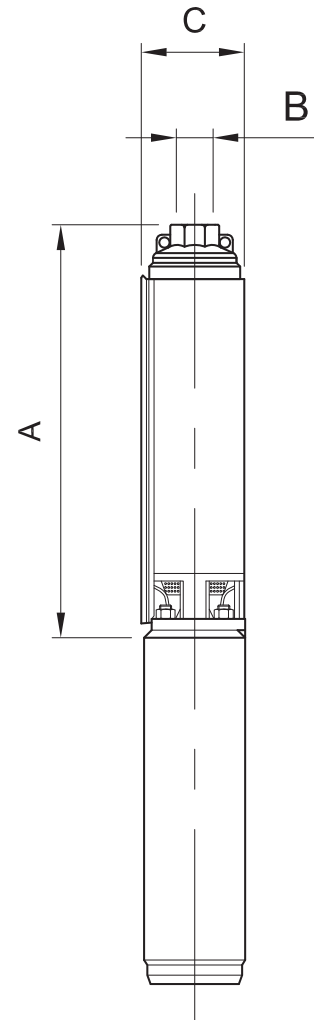
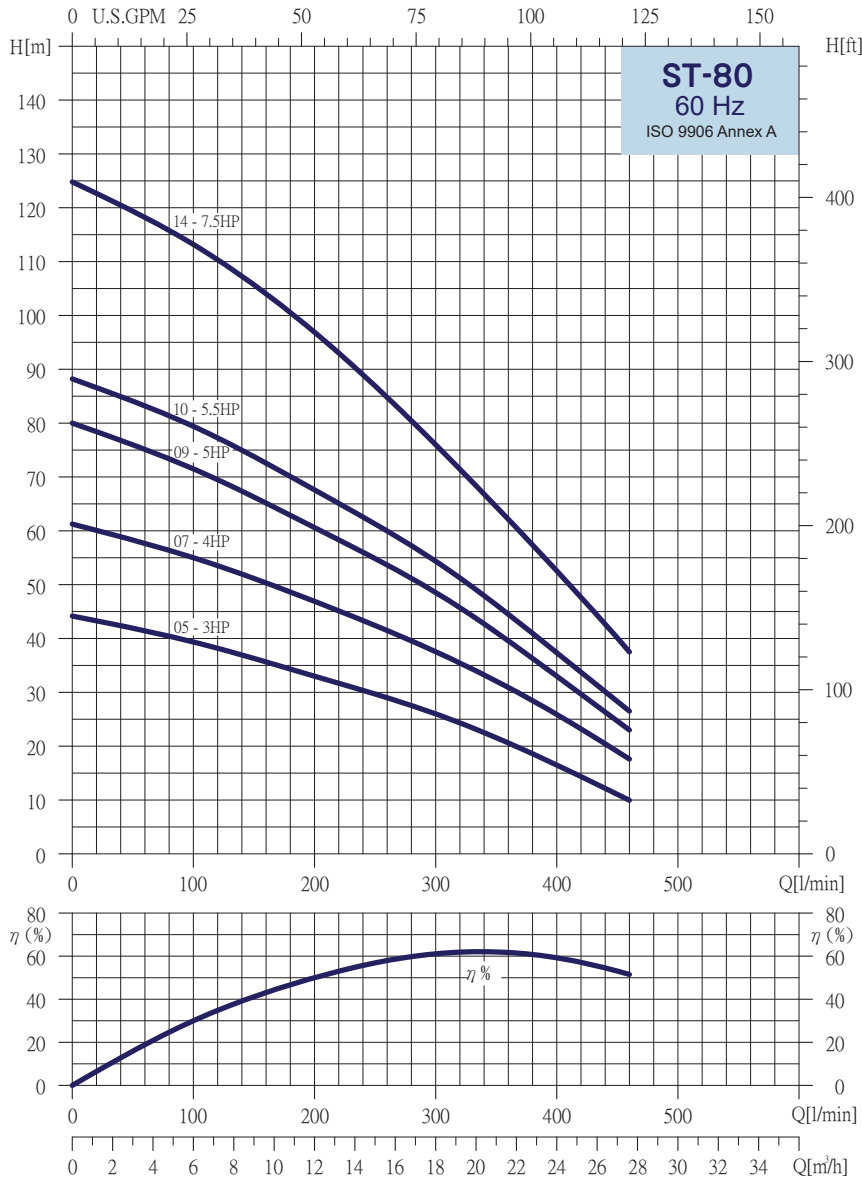

Selection Chart																	
PUMP TYPE	STAGES	MOTOR		Q=DELIVERY													
		KW	HP	l/min	140	160	180	200	220	240	260	280	300	340	380	420	460
				m³/h	8.4	9.6	10.8	12	13.2	14.4	15.6	16.8	18	20.4	22.8	25.2	27.6
H=TOTAL HEAD IN METERS																	
ST-8005	5	2.2	3.0	44		36	34	33	32	30	29	28	26	23	19	14	10
ST-8007	7	3.0	4.0	61		50	49	47	45	43	41	40	38	33	28	23	18
ST-8009	9	3.7	5.0	80		65	63	61	58	56	54	51	49	43	36	30	23
ST-8010	10	4.0	5.5	88		73	70	68	65	63	60	57	54	48	41	34	27
ST-8014	14	5.5	7.5	126		104	101	97	93	89	85	80	76	67	62	48	38

Dimensions and Weights				
Pump Type	Dimensions(mm)			N.W (kg)
	A	B	C	
ST-8005	472	RP : 2" NPT : 2"	98	4.4
ST-8007	608		98	5.6
ST-8009	743		98	6.9
ST-8010	814		98	7.5
ST-8014	1081		98	9.9

# 6" ST Submersible Pump



## Model code

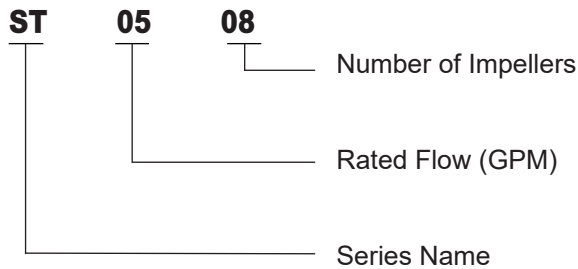

### Description

The 6" submersible pumps for high pressures and flow rates, particularly equipped with a high rigidity **Silicon-Carbide(SiC) Bearing**, provide reliability and quality guaranteed.

### APPLICATIONS

- Water Supply
- Irrigation
- Pressure Boosting

### GENERAL SPECIFICATIONS PUMP

- Delivery: up to 72 m<sup>3</sup>/h at 3450 rpm
- Head: up to 430 m at 3450 rpm
- Maximum permissible quantity of sand: 60g/m<sup>3</sup>
- ST 50-ST75-ST135-ST180-ST220 models 3" discharge.

**Discharge Head and Motor Adaptor** are precision machined cast 304 stainless steel for superior strength and durability. The motor adaptor is NEMA standard.

### Impellers are made with Noryl®

For a superior sand handling. Together with glass filled polycarbonate diffusers make the super strong pumps for maximum wear and abrasive resistance. The materials are FDA compliant materials.

**Impeller Bowls** are made from 304 stainless steel, maximizing wear from abrasion.

**Shaft Coupling** is made from 304 stainless steel for easy alignment to the motor shaft.

**Strainer** is made from stamped 304 stainless steel for rigidity.

**Non-Return valve** made from 304 stainless steel, fitted in the discharge to prevent any back flow of water and alleviate any water hammer to the pumps.

**Pump Shaft** is made from hex 304 stainless steel bar material for high corrosion resistance.

**Pump body** is covered by a thick 304 stainless steel casing, ensures optimum resistance to abrasion.



# Performance range

ST 6"

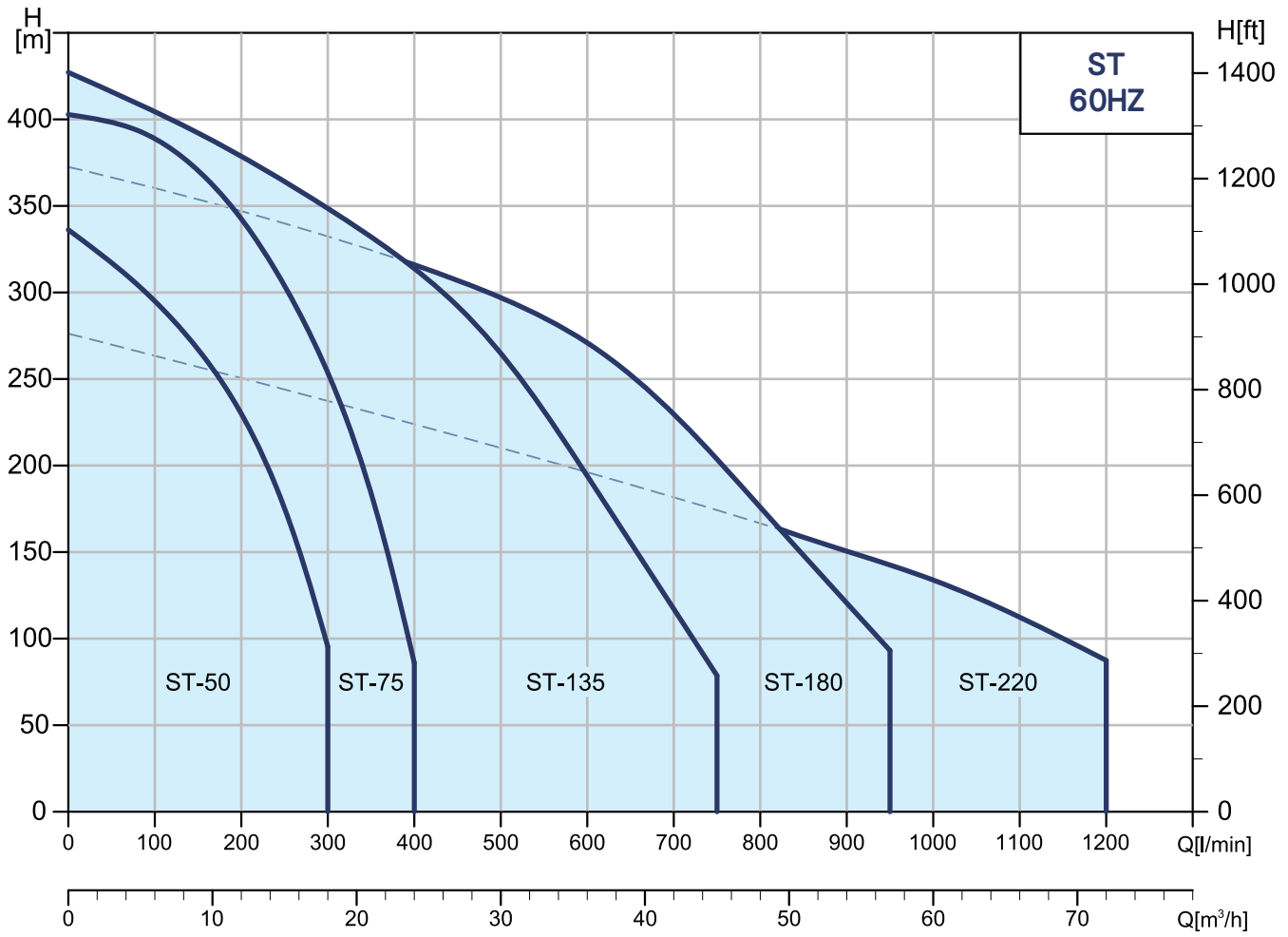

# Material Specification

ST 6"

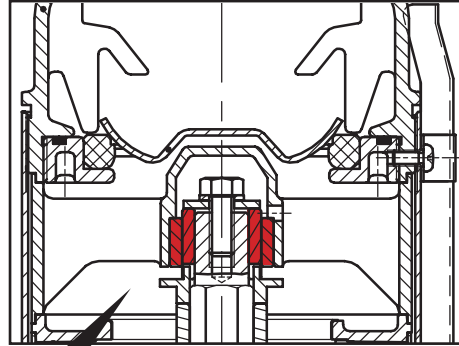
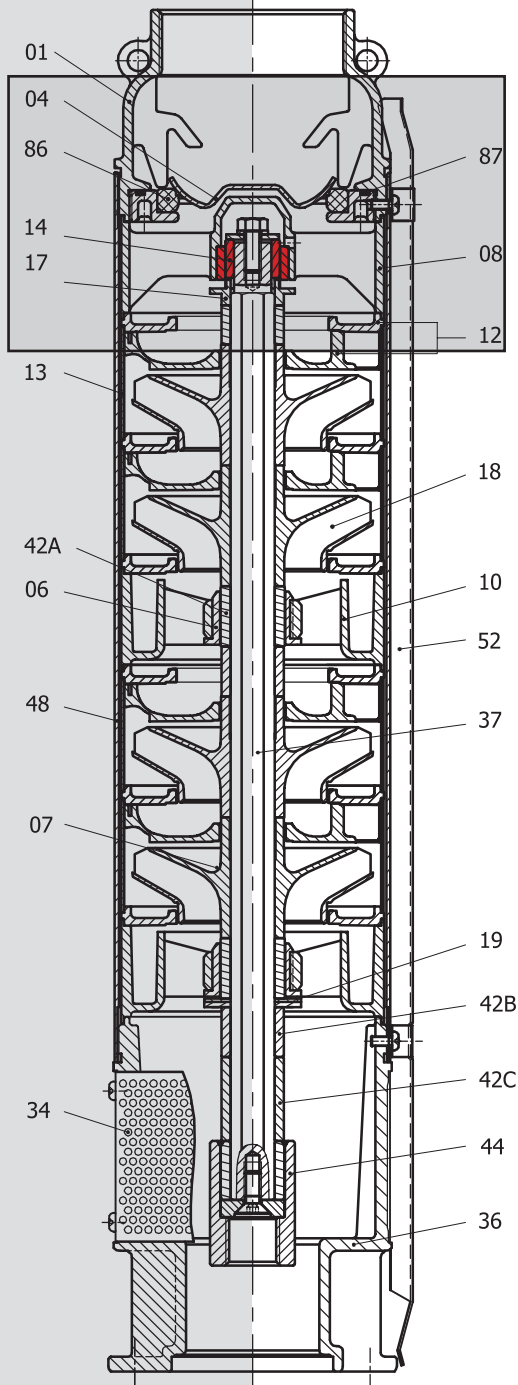

High rigidity **Silicon-Carbide(SiC) Bearing** ensure high corrosion resistance and provide long and dependable service life.

Pos.	Part Name	Material
1	Discharge	AISI 304
4	Valve cone	AISI 304
6	Bearing	POM+PTFE
7	Bearing	Bronze
8	Upper bearing spider	AISI 304 + Silicon carbide
10	Bearing Spider	Noryl
12	Diffuser	Glass Filled Polycarbonate
13	Diffuser casing	AISI 304
14	Bearing ring	Silicon carbide
17	Sleeve for baffle	AISI 304
18	Impeller	Noryl
19	Counter thrust bearing plate	Carbon fiber + PTFE
34	Strainer	AISI 304
36	Suction interconnector	AISI 304
37	Pump shaft	AISI 304
42A	Shaft sleeve	AISI 304
42B	Shaft sleeve	Noryl
42C	Shaft sleeve	Noryl
44	Coupling	AISI 304
48	Pump casing	AISI 304
52	Cable guard	AISI 304
86	Valve Seat	AISI 304 + NBR
87	O-ring	NBR

# Performance Curves

ST 6"

# ST-50

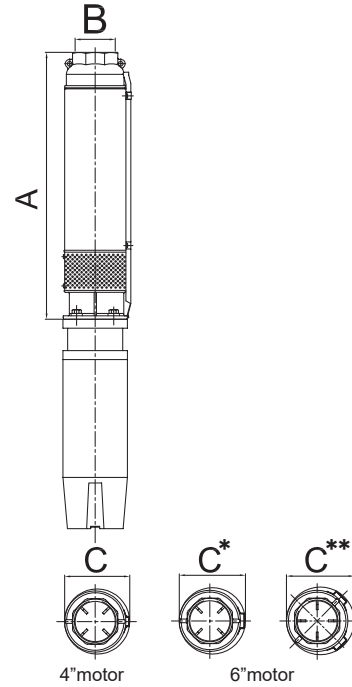
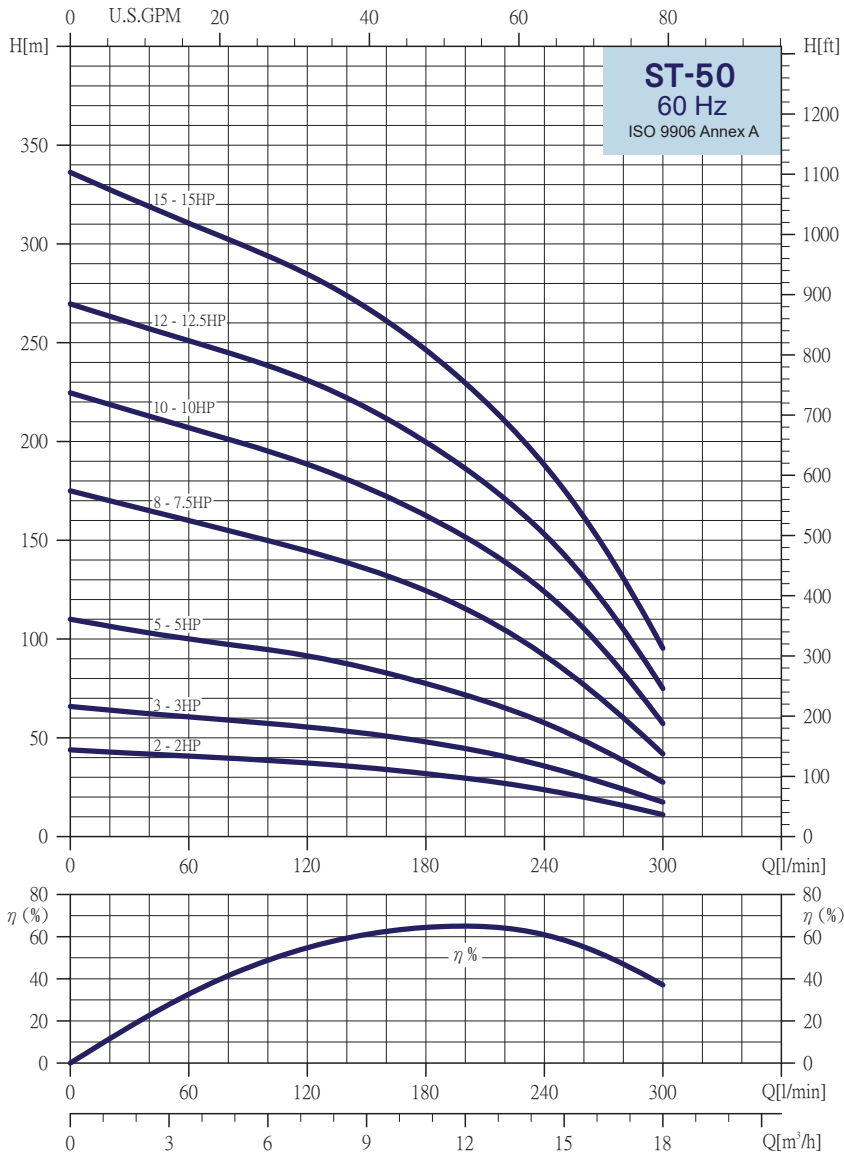

## Dimensions and weights

Pump type	Motor			Dimensions (mm)					Weight (kg)
	Power	HP	Type	A	B	C	C*	C**	
ST 50-2	1.5	2	4"	425	NPT3" RP3"	138			8.2
ST 50-3	2.2	3	4"	463		138			8.9
ST 50-5	3.7	5	4"	539		138			10.3
ST 50-8	5.5	7.5	4"	653		138			12.5
ST 50-10	7.5	10	4"	729		138			13.8
ST 50-8	5.5	7.5	6"	667			141	144	13.2
ST 50-10	7.5	10	6"	743			141	144	14.6
ST 50-12	9.3	12.5	6"	819			141	144	15.9
ST 50-15	11	15	6"	933			141	144	17.8

## Selection Chart

Pump Type	Q=DELIVERY										
	l/min 0	120	140	160	180	200	220	240	260	280	300
	m³/h 0	7.2	8.4	9.6	10.8	12	13.2	14.4	15.6	16.8	18
H=TOTAL HEAD IN METERS											
ST 50-02	44	37	35	34	32	29	27	23	20	15	11
ST 50-03	66	55	53	51	48	44	40	35	30	24	17
ST 50-05	110	91	87	83	77	71	65	57	48	38	27
ST 50-08	175	144	138	132	124	115	104	91	77	60	42
ST 50-10	224	188	181	172	162	151	139	124	105	83	57
ST 50-12	269	231	222	211	200	186	171	153	131	105	75
ST 50-15	336	284	274	261	246	229	210	188	161	130	95

# Performance Curves

ST 6"

# ST-75

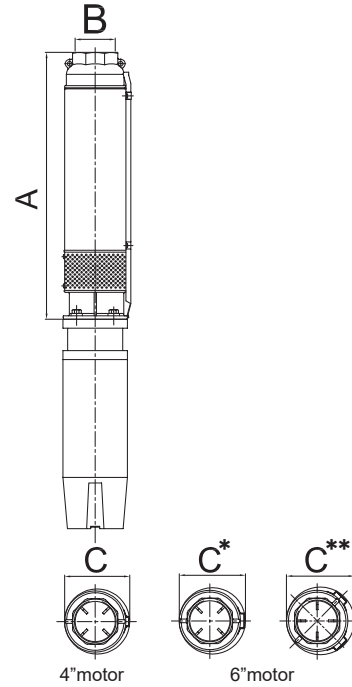
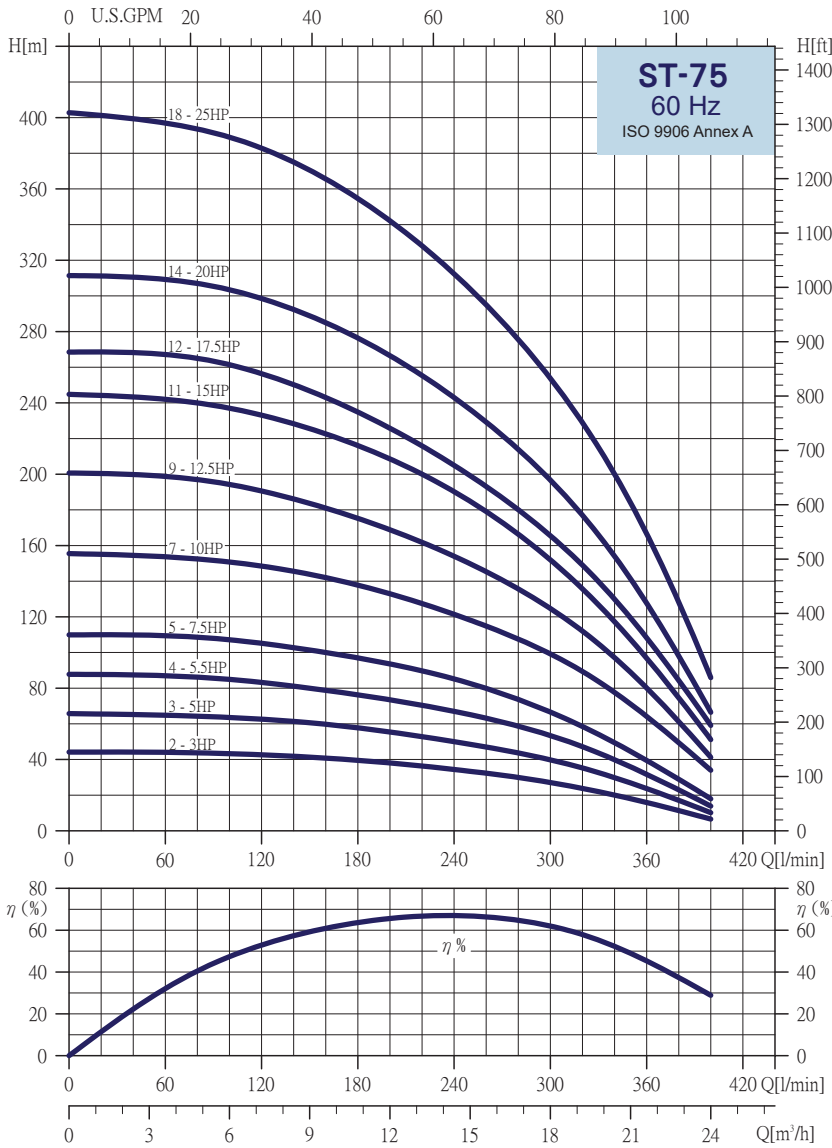

## Dimensions and weights

Pump type	Motor			Dimensions(mm)				Weight(kg)	
	Power		Type	A	B	C	C*		C**
	kW	HP							
ST 75-2	2.2	3	4"	425	NPT3" RP3"	138			8.2
ST 75-3	3.7	5	4"	463		138			8.9
ST 75-4	4	5.5	4"	501		138			9.6
ST 75-5	5.5	7.5	4"	539		138			10.3
ST 75-7	7.5	10	4"	615		138			11.7
ST 75-5	5.5	7.5	6"	553			141	144	11.1
ST 75-7	7.5	10	6"	629			141	144	12.5
ST 75-9	9.3	12.5	6"	705			141	144	13.9
ST 75-11	11	15	6"	781			141	144	15.2
ST 75-12	13	17.5	6"	819			141	144	15.8
ST 75-14	15	20	6"	895			141	144	17.2
ST 75-18	18.5	25	6"	1047			141	144	19.9

## Selection Chart

Pump Type	Q=DELIVERY												
	l/min 0	160	180	200	220	240	260	280	300	320	340	360	380
	m³/h 0	9.6	10.8	12	13.2	14.4	15.6	16.8	18	19.2	20.4	21.6	22.8
H=TOTAL HEAD IN METERS													
ST 75-02	44	41	39	38	36	34	32	30	27	24	20	16	11
ST 75-03	65	59	57	55	53	50	47	43	40	35	30	23	17
ST 75-04	87	78	76	73	70	67	63	58	53	47	40	31	23
ST 75-05	110	100	97	93	89	85	80	73	66	58	49	39	29
ST 75-07	155	142	137	133	127	121	115	107	99	89	77	64	49
ST 75-09	200	181	175	169	162	154	145	135	124	112	97	80	61
ST 75-11	244	222	216	208	200	190	179	166	152	135	117	97	74
ST 75-12	268	243	235	226	216	205	193	180	165	149	130	108	84
ST 75-14	311	285	276	266	255	243	229	214	196	177	154	127	98
ST 75-18	402	365	354	342	328	312	295	275	253	229	200	166	128

# Performance Curves

ST 6"

# ST-135

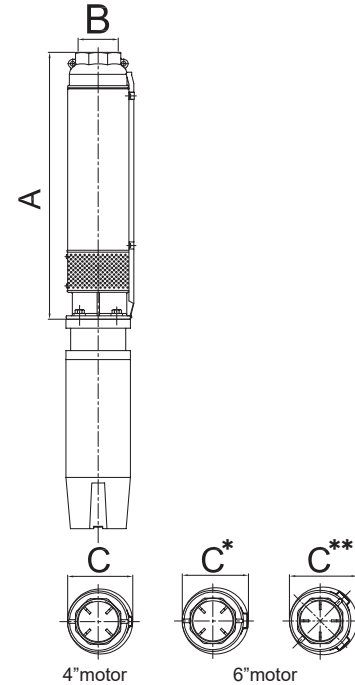
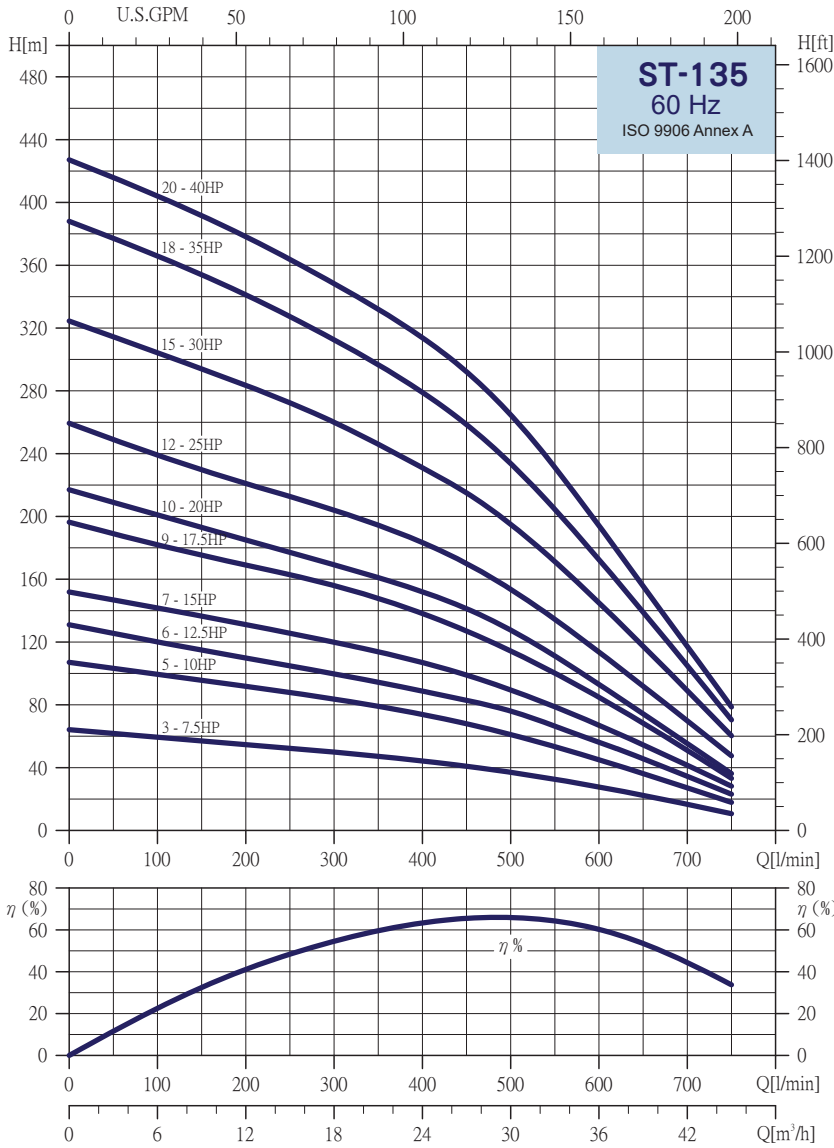

## Dimensions and weights

Pump type	Motor		Type	Dimensions(mm)					Weight(kg)
	Power	kW		NPT3*					
				A	B	C	C*	C**	
ST 135-3	5.5	7.5	4"	520		138			9.9
ST 135-5	7.5	10	4"	634		138			11.8
ST 135-3	5.5	7.5	6"	534			141	144	10.7
ST 135-5	7.5	10	6"	648			141	144	12.5
ST 135-6	9.3	12.5	6"	705			141	144	13.5
ST 135-7	11	15	6"	762			141	144	14.4
ST 135-9	13	17.5	6"	876			141	144	16.1
ST 135-10	15	20	6"	933			141	144	17
ST 135-12	18.5	25	6"	1047			141	144	18.9
ST 135-15	22	30	6"	1218			141	144	21.6
ST 135-18	26	35	6"	1389			141	144	24.3
ST 135-20	30	40	6"	1555			141	144	27

## Selection Chart

Pump Type	Q=DELIVERY												
	l/min 0	200	250	300	350	400	450	500	550	600	650	700	750
	m³/h 0	12	15	18	21	24	27	30	33	36	39	42	45
H=TOTAL HEAD IN METERS													
ST 135-03	64	54	52	50	47	44	41	37	32	27	22	16	10
ST 135-05	107	91	88	83	79	74	68	61	53	45	36	27	18
ST 135-06	131	109	105	99	94	88	83	76	66	56	45	34	23
ST 135-07	152	131	125	120	113	107	99	89	78	67	54	41	28
ST 135-09	196	169	162	156	147	138	127	114	100	85	68	51	33
ST 135-10	217	185	177	169	161	152	141	127	111	93	74	55	36
ST 135-12	259	221	212	204	194	183	170	153	134	113	92	70	47
ST 135-15	324	283	272	260	246	231	215	195	171	145	117	89	60
ST 135-18	388	341	327	312	296	279	258	233	204	172	139	105	70
ST 135-20	427	378	363	348	332	314	292	264	231	194	155	117	78

# Performance Curves

ST 6"

# ST-180

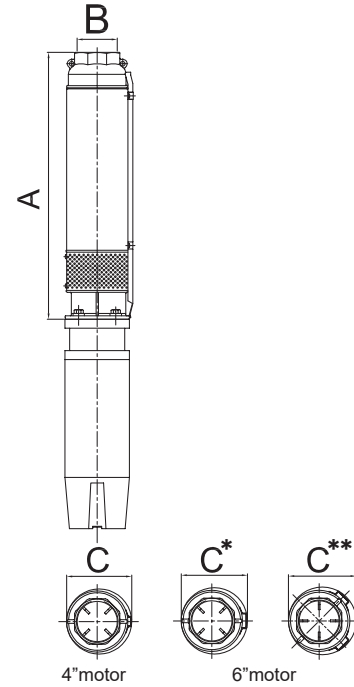
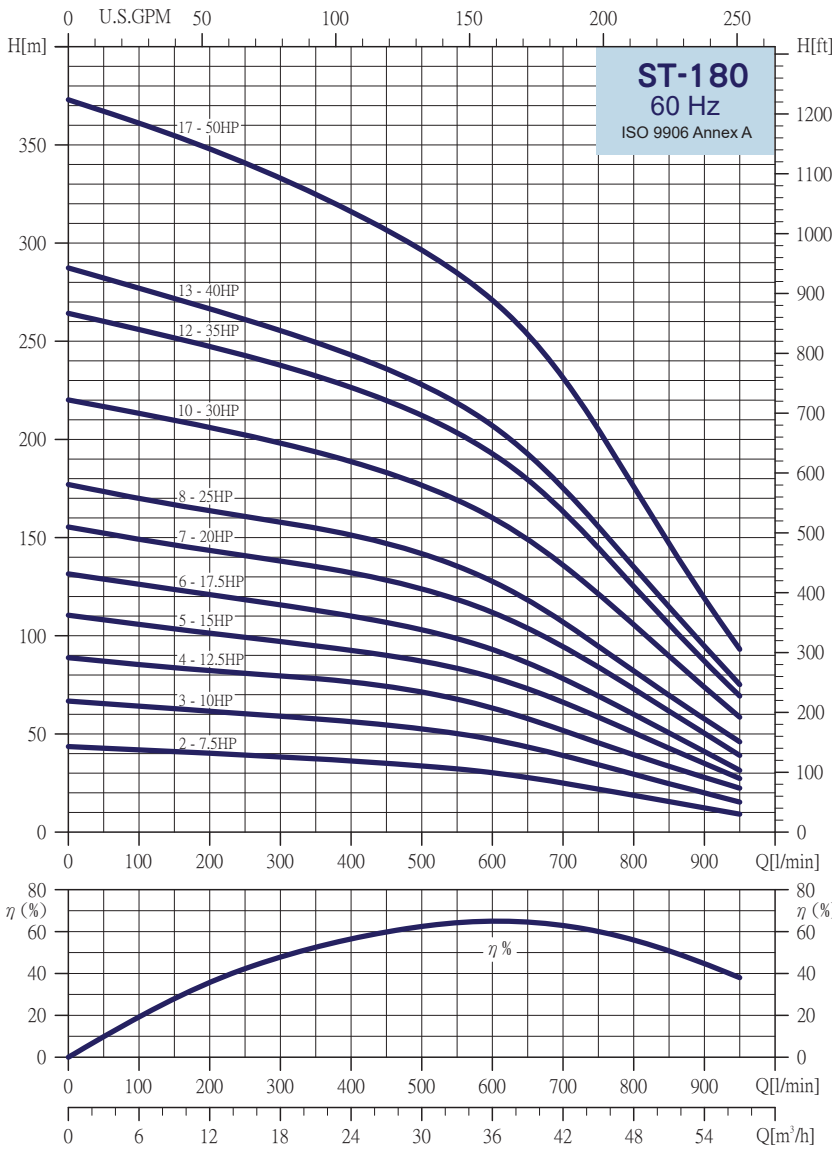

## Dimensions and weights

Pump type	Motor		Type	Dimensions(mm)				Weight(kg)	
	Power kW	HP		A	B	C			
						C*	C**		
ST 180-2	5.5	7.5	4"	469	NPT3" RP3"	138			8.9
ST 180-3	7.5	10	4"	529		138			9.9
ST 180-2	5.5	7.5	6"	483			141	144	9.8
ST 180-3	7.5	10	6"	543			141	144	10.7
ST 180-4	9.3	12.5	6"	603			141	144	11.6
ST 180-5	11	15	6"	663			141	144	12.6
ST 180-6	13	17.5	6"	723			141	144	13.6
ST 180-8	18.5	25	6"	843			141	144	15.5
ST 180-10	22	30	6"	963			141	144	17.4
ST 180-12	26	35	6"	1083			141	144	19.2
ST 180-13	30	40	6"	1143			141	144	20.3
ST 180-17	37	50	6"	1435			141	144	24.9

## Selection Chart

Pump Type	Q=DELIVERY												
	l/min 0	350	400	450	500	550	600	650	700	750	800	850	900
	m³/h 0	21	24	27	30	33	36	39	42	45	48	51	54
H=TOTAL HEAD IN METERS													
ST 180-02	43	37	36	35	33	32	30	28	25	22	18	15	12
ST 180-03	66	57	56	54	52	50	47	43	39	34	29	24	20
ST 180-04	89	78	76	74	71	67	63	57	51	45	39	33	28
ST 180-05	110	95	93	90	87	83	79	73	66	58	50	42	35
ST 180-06	131	113	110	106	103	98	93	86	78	69	60	50	41
ST 180-07	155	135	132	128	124	118	112	104	94	84	73	61	50
ST 180-08	177	155	151	147	142	135	127	118	107	94	82	69	57
ST 180-10	220	193	189	183	176	169	160	149	136	121	105	89	74
ST 180-12	264	232	226	220	212	203	192	179	163	144	125	105	87
ST 180-13	287	249	243	236	228	218	207	192	175	155	135	114	94
ST 180-17	373	324	316	306	296	284	271	253	231	205	176	147	119

# Performance Curves

ST 6"

# ST-220

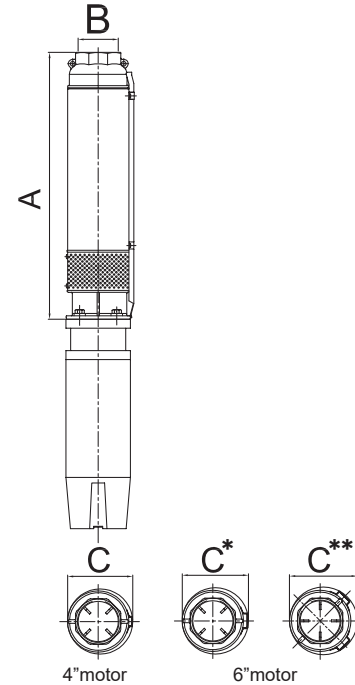
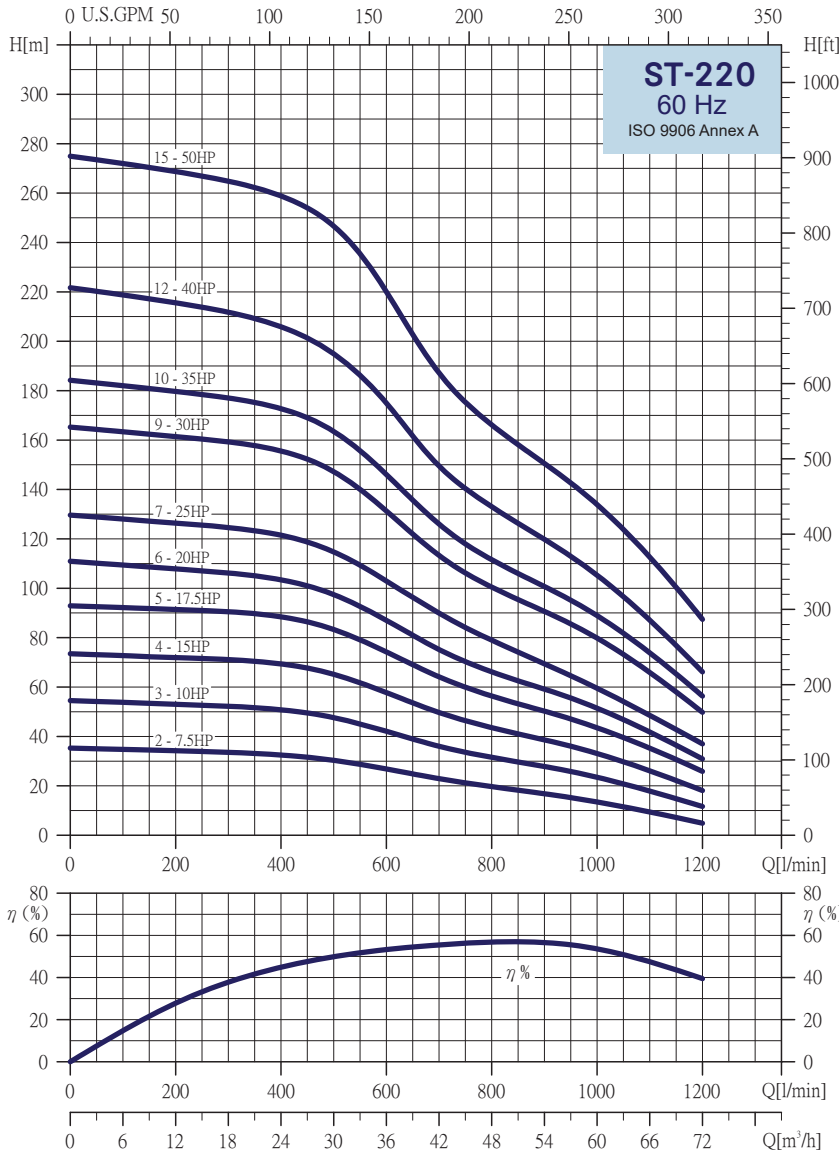

## Dimensions and weights

Pump type	Motor			Dimensions(mm)					Weight(kg)
	kW	HP	Type	A	B	C	C*	C**	
ST 220-2	5.5	7.5	4"	469	NPT3"	138			8.9
ST 220-3	7.5	10	4"	529		138			9.9
ST 220-2	5.5	7.5	6"	483			141	144	9.8
ST 220-3	7.5	10	6"	543			141	144	10.7
ST 220-4	11	15	6"	603			141	144	11.7
ST 220-5	13	17.5	6"	663			141	144	12.6
ST 220-7	18.5	25	6"	783		RP3"	141	144	14.5
ST 220-9	22	30	6"	903			141	144	16.5
ST 220-10	26	35	6"	963			141	144	17.5
ST 220-12	30	40	6"	1083			141	144	19.5
ST 220-15	37	50	6"	1263			141	144	22.6

## Selection Chart

Pump Type	Q=DELIVERY													
	l/min 0	450	500	550	600	650	700	750	800	850	900	1000	1100	1200
	m³/h 0	27	30	33	36	39	42	45	48	51	54	60	66	72
H=TOTAL HEAD IN METERS														
ST 220-02	35	31	30	28	27	25	23	21	19	18	16	13	9	5
ST 220-03	54	49	47	45	42	39	36	33	31	29	28	23	17	11
ST 220-04	73	67	65	61	57	53	49	46	43	41	38	33	26	18
ST 220-05	93	86	83	79	74	69	64	60	56	53	50	43	35	26
ST 220-06	111	101	97	92	87	81	75	70	66	62	59	51	41	31
ST 220-07	129	118	114	109	103	96	90	84	79	74	69	59	48	37
ST 220-09	165	152	147	140	131	122	113	106	100	95	90	80	66	50
ST 220-10	184	169	163	155	146	135	126	118	111	106	100	89	74	56
ST 220-12	221	201	195	186	175	161	149	140	133	126	120	105	87	66
ST 220-15	275	254	246	235	220	202	187	175	166	158	150	134	112	87



[www.sistema-pumps.com](http://www.sistema-pumps.com)