



ST Submersible Pumps

Made in Taiwan



Catalogue 50 Hz

4" ST Submersible Pump



Model code

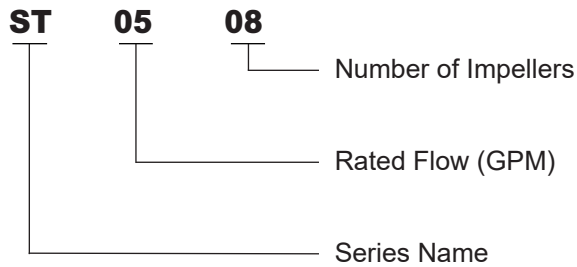

APPLICATIONS

- Water Supply
- Irrigation
- Pressure Boosting

GENERAL SPECIFICATIONS PUMP

- Delivery: up to 24 m³/h at 2850 rpm
- Head: up to 322 m at 2850 rpm
- Maximum permissible quantity of sand: 150g/m³
- ST05-ST07-ST10-ST13-ST18 models 1 ¼" discharge.
- ST25 model 1½" discharge.
- ST35-ST40-ST55-ST60-ST80 models 2" discharge.

Discharge Head and Motor Adaptor are precision machined cast 304 stainless steel for superior strength and durability. The motor adaptor is NEMA standard.

Impellers are floating type made with Noryl® for a superior sand handling. Together with glass filled polycarbonate diffusers make the super strong pumps for maximum wear and abrasive resistance. The materials are FDA compliant materials.

Impeller Bowls are made from 304 stainless steel, maximizing wear from abrasion.

Shaft Coupling is made from 304 stainless steel for easy alignment to the motor shaft.

Strainer is made from stamped 304 stainless steel for rigidity.

Non-Return valve made from 304 stainless steel, fitted in the discharge to prevent any back flow of water and alleviate any water hammer to the pumps.

Pump Shaft is made from hex 304 stainless steel bar material for high corrosion resistance.

Bearing is made with Polyacetal for strong wear and abrasive resistance.

Pump body is covered by a 1.5mm thick 304 polished stainless steel casing, ensures optimum resistance to abrasion.

Performance range

ST 4"

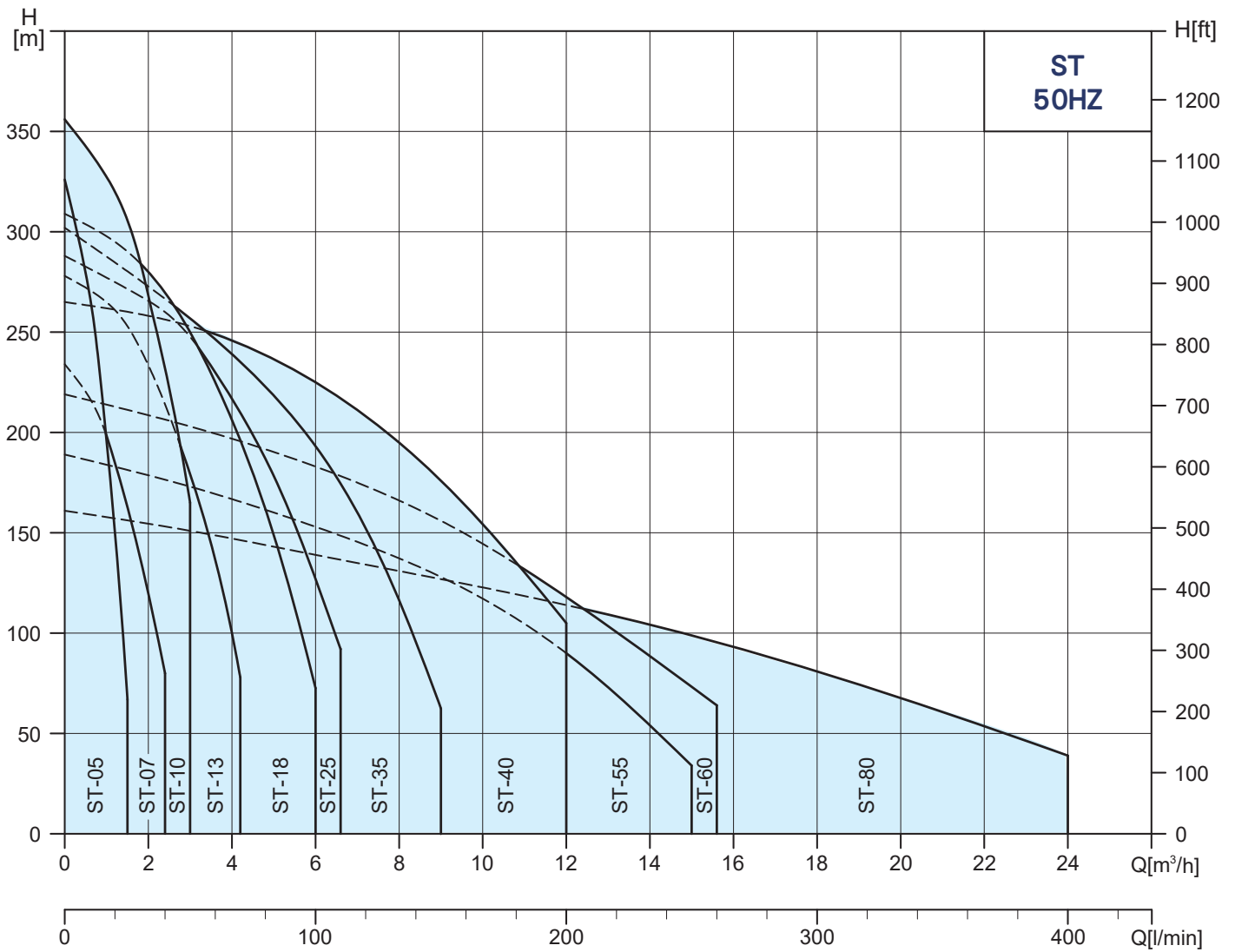

Material Specification



ST 4"

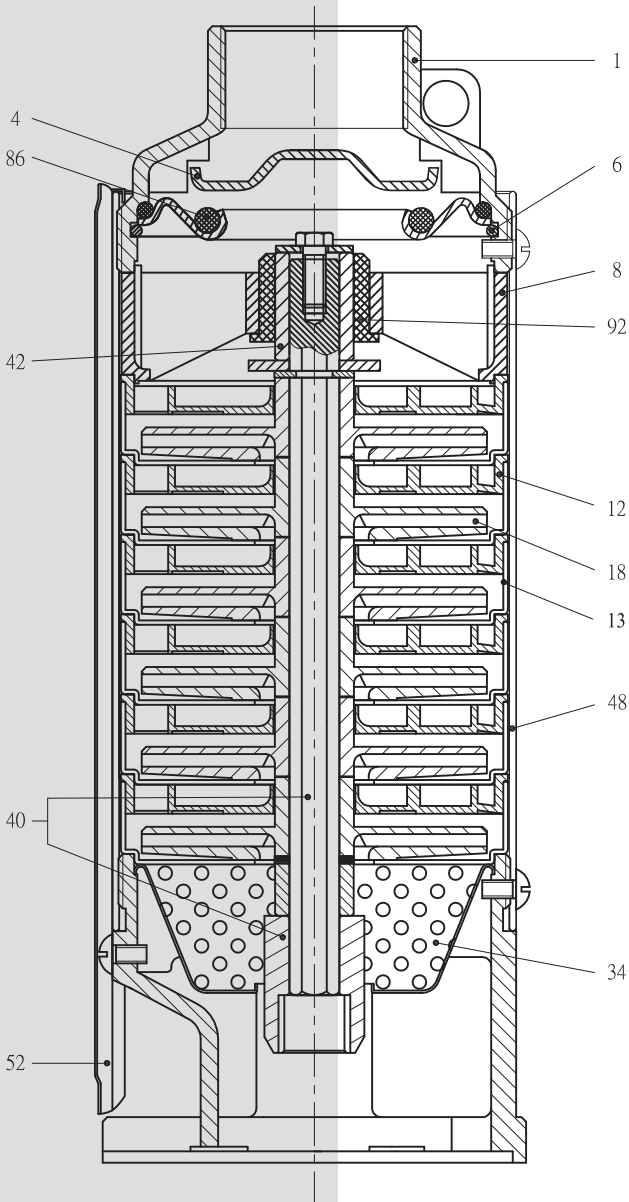

Pos.	Part Name	Material
1	Discharge Head	AISI 304 SS
4	Check Valve Cone	AISI 304 SS
6	Check Valve retaining Ring	AISI 304 SS
8	Bearing Spider	Glass Filled Polycarbonate
12	Diffuser	Glass Filled Polycarbonate
13	Bowl	AISI 304 SS
18	Impeller	Noryl
34	Strainer	AISI 304 SS
40	Pump Shaft / Coupling	AISI 304 SS
42	Shaft Sleeve	AISI 304 SS or Noryl
48	Pump Casing	AISI 304 SS
52	Cable Guard	AISI 304 SS
86	O-Ring	NBR
92	Bearing	Polyacetal

Performance Curves

ST-05

ST 4"

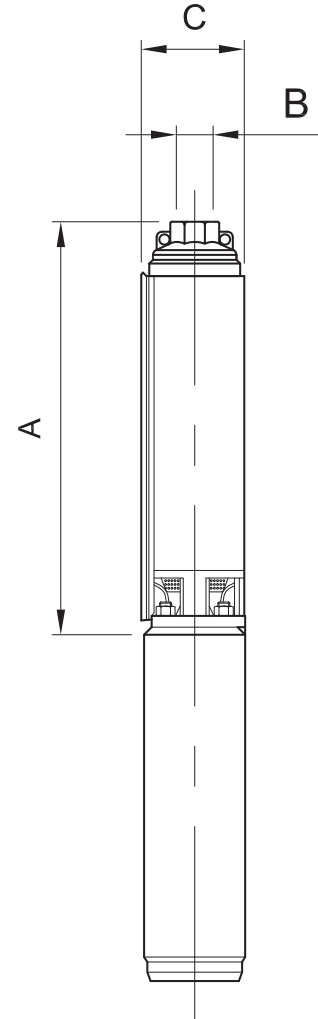
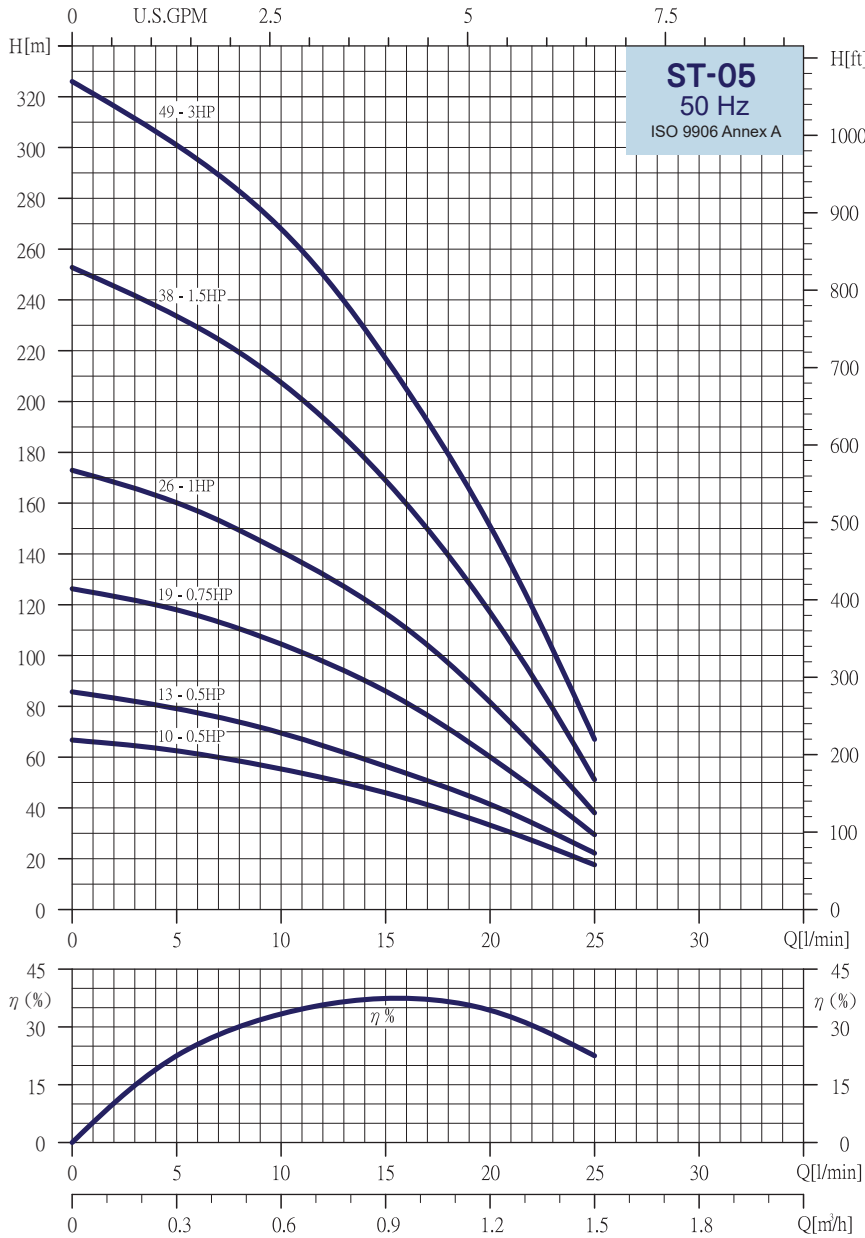

Selection Chart

PUMP TYPE	STAGES	MOTOR		Q=DELIVERY					
				l/min	5	10	15	20	25
		KW	HP	m³/h	0.3	0.6	0.9	1.2	1.5
H=TOTAL HEAD IN METERS									
ST-0510	10	0.37	0.5	67	63	55	46	33	18
ST-0513	13	0.37	0.5	86	78	70	56	42	23
ST-0519	19	0.55	0.75	126	118	105	86	60	30
ST-0526	26	0.75	1.0	173	160	141	117	81	39
● ST-0538	38	1.1	1.5	253	234	208	169	117	52
● ST-0549	49	2.2	3.0	326	301	268	219	151	67

Dimensions and Weights

Pump Type	Dimensions(mm)			N.W (kg)
	A	B	C	
ST-0510	324	RP : 1¼" NPT :	98	3.3
ST-0513	377		98	3.7
ST-0519	481		98	4.7
ST-0526	642		98	5.8
ST-0538	910		98	9.2
ST-0549	1105		98	12.5

The ● means outer sleeve made by 2 pieces

Performance Curves

ST 4"

ST-07

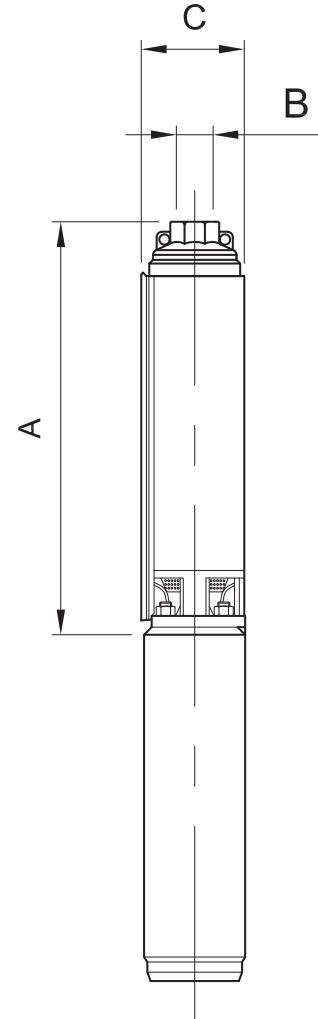
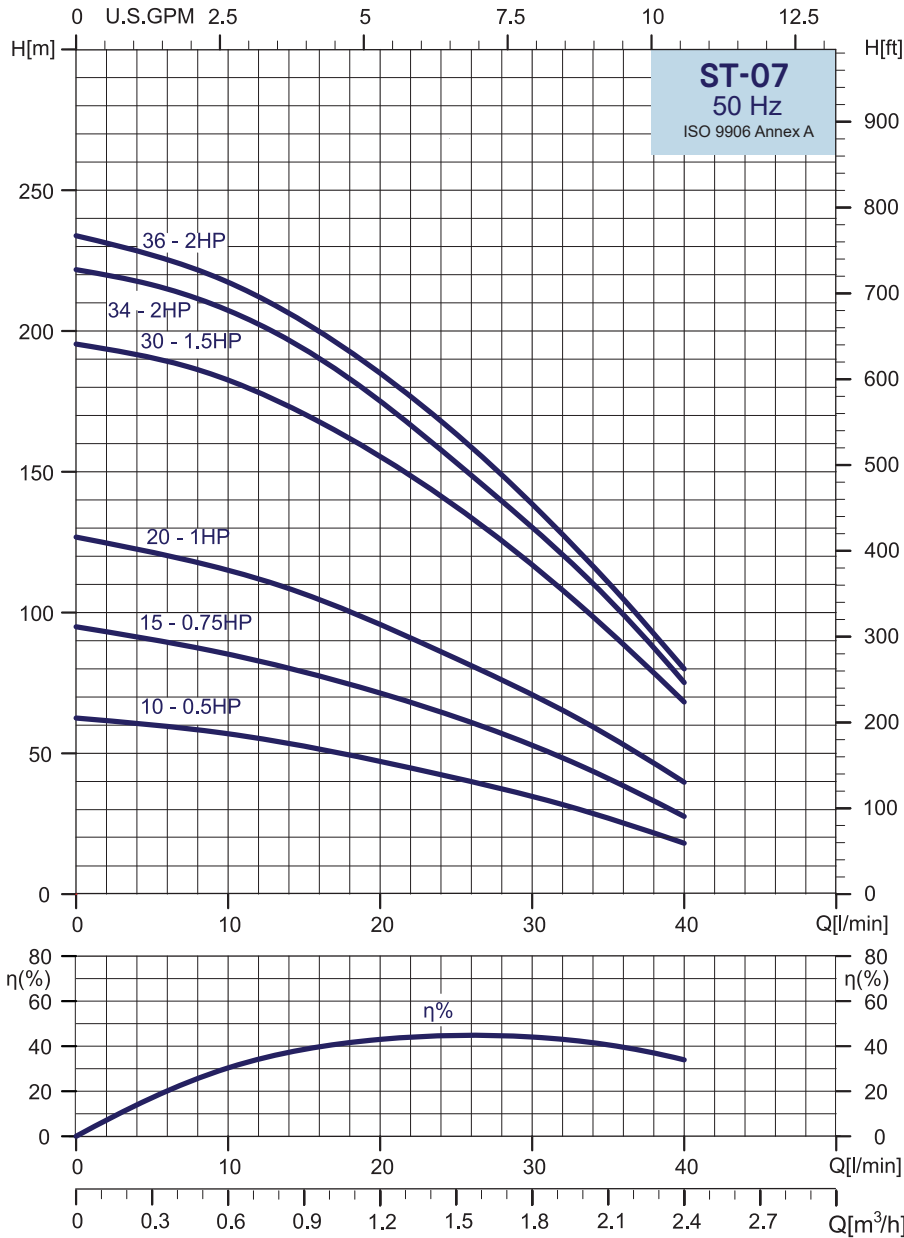

Selection Chart

PUMP TYPE	STAGES	MOTOR		Q=DELIVERY									
		KW	HP	H=TOTAL HEAD IN METERS									
				l/min 0	5	10	15	20	25	30	35	40	
ST-0710	10	0.37	0.5	63		57	53	47	42	35	27	18	
ST-0715	15	0.55	0.75	95		86	78	72	63	53	41	28	
ST-0720	20	0.75	1	127		115	107	96	84	71	56	40	
ST-0730	30	1.1	1.5	195		183	171	156	138	117	94	69	
● ST-0734	34	1.5	2	222		207	194	175	154	130	104	76	
● ST-0736	36	1.5	2	234		217	203	185	164	138	110	80	

Dimensions and Weights

Pump Type	Dimensions (mm)			N.W (kg)
	A	B	C	
ST-0710	330	RP : 1/4" NPT:	98	3.3
ST-0715	420		98	4.3
ST-0720	510		98	5.3
ST-0730	730		98	7.4
ST-0734	858		98	9.3
ST-0736	895		98	9.8

The ● means outer sleeve made by 2 pieces

Performance Curves

ST 4"

ST-10

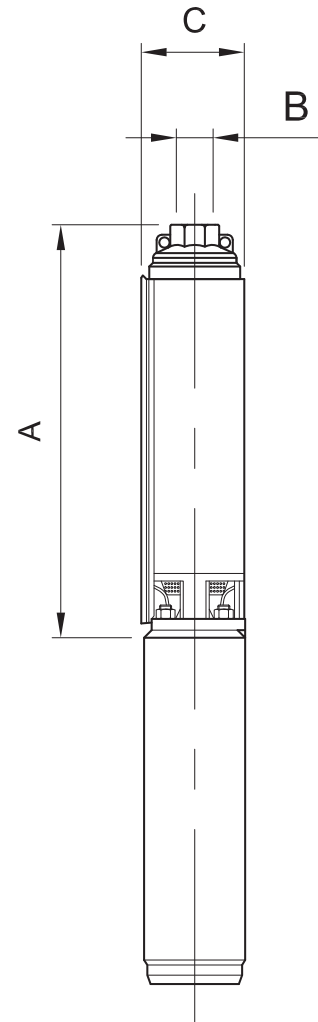
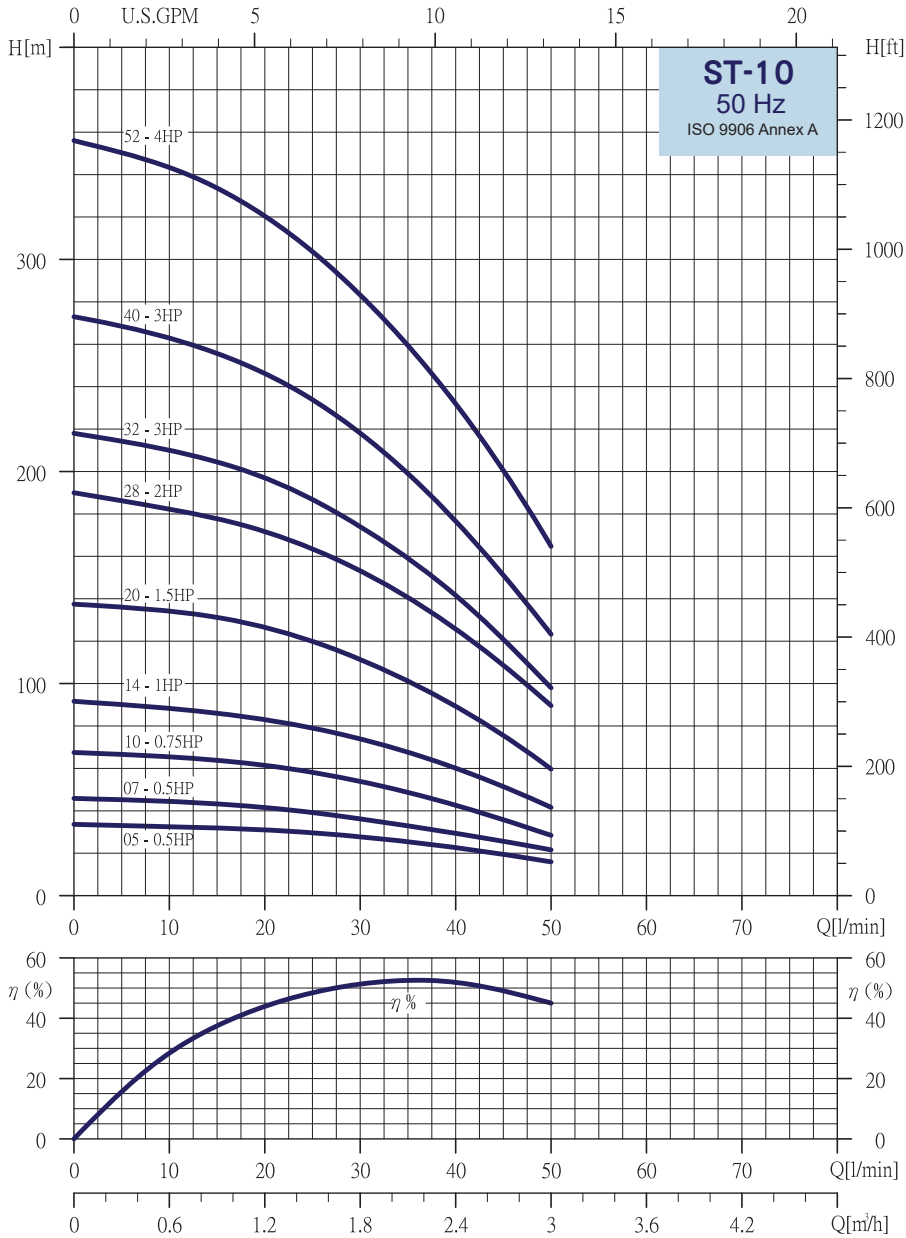

Selection Chart

PUMP TYPE	STAGES	MOTOR		Q=DELIVERY												
		KW	HP	l/min	5	10	15	20	25	30	35	40	45	50		
				m ³ /h	0.3	0.6	0.9	1.2	1.5	1.8	2.1	2.4	2.7	3.0		
H=TOTAL HEAD IN METERS																
ST-1005	5	0.37	0.5	34			32	31	29	27	25	23	19	16		
ST-1007	7	0.37	0.5	46			43	42	39	36	33	29	26	22		
ST-1010	10	0.55	0.75	67			64	61	58	54	49	43	36	28		
ST-1014	14	0.75	1	92			86	83	79	74	67	60	52	42		
ST-1020	20	1.1	1.5	139			131	127	120	111	101	90	75	60		
ST-1028	28	1.5	2	190			178	172	163	153	141	126	108	89		
● ST-1032	32	2.2	3.0	218			205	197	187	174	159	142	121	98		
● ST-1040	40	2.2	3.0	273			256	246	234	218	199	177	151	123		
● ST-1052	52	3.0	4	356			334	320	304	283	259	232	201	165		

Dimensions and Weights

Pump Type	Dimensions(mm)			N.W (kg)
	A	B	C	
ST-1005	236	RP : 1/4" NPT:	98	2.5
ST-1007	271		98	2.8
ST-1010	324		98	3.3
ST-1014	394		98	3.9
ST-1020	499		98	4.9
ST-1028	679		98	7.1
ST-1032	787		98	7.8
ST-1040	950		98	10.5
ST-1052	1235		98	13.5

The ● means outer sleeve made by 2 pieces

Performance Curves

ST 4"

ST-13

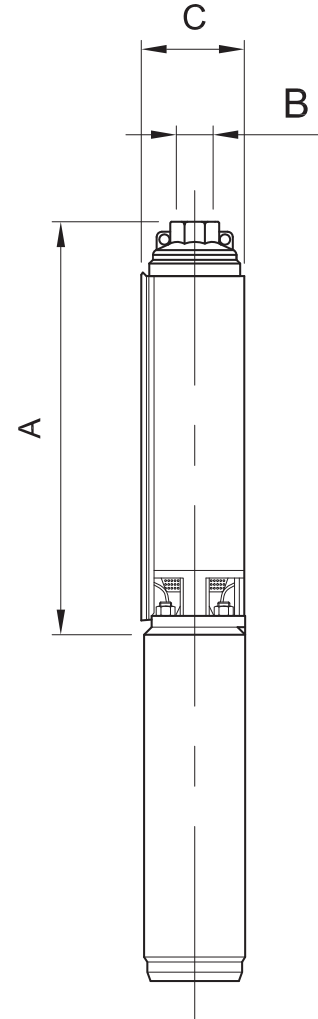
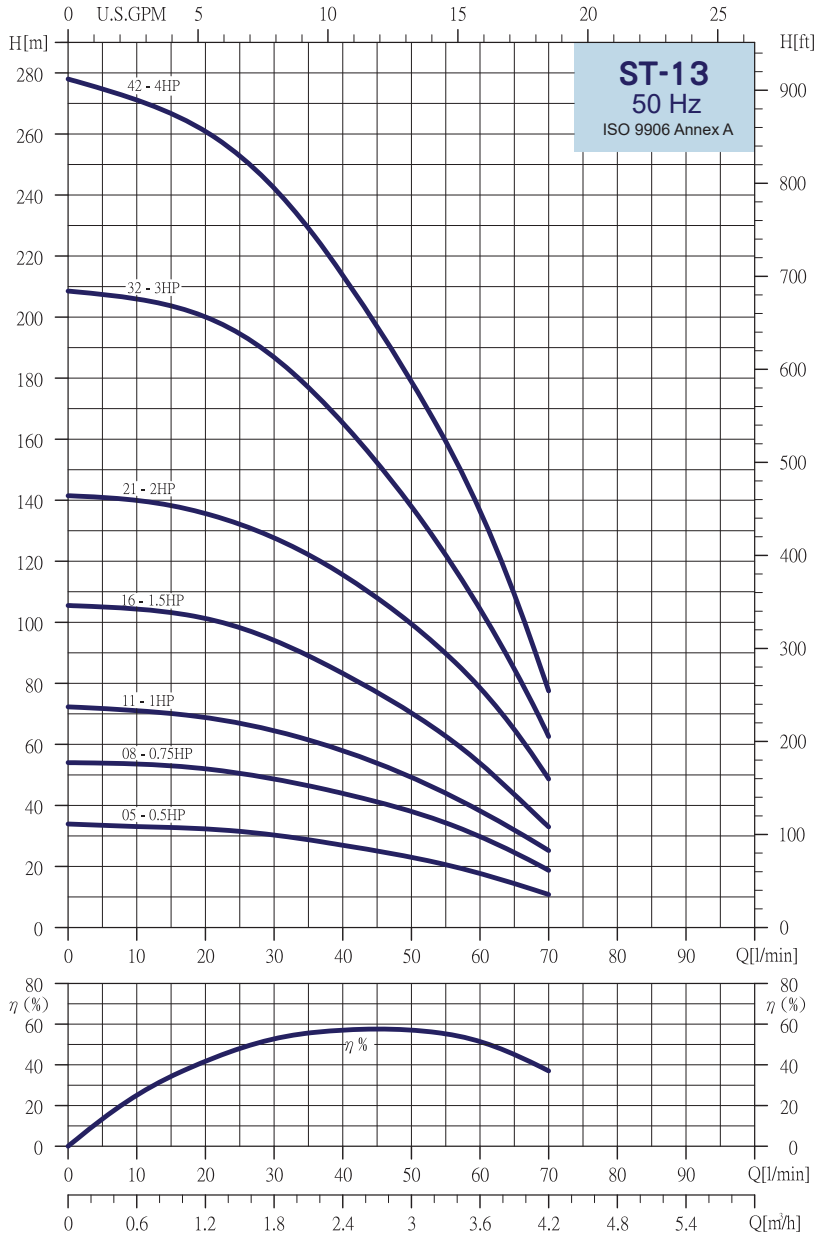

Selection Chart																	
PUMP TYPE	STAGES	MOTOR		Q=DELIVERY													
				l/min	5	10	15	20	25	30	35	40	45	50	60	70	
		m³/h	0.3	0.6	0.9	1.2	1.5	1.8	2.1	2.4	2.7	3	3.6	4.2			
H=TOTAL HEAD IN METERS																	
ST-1305	5	0.37	0.5	34				32	31	30	29	27	25	23	18	11	
ST-1308	8	0.55	0.75	54				51	50	49	46	43	41	38	30	19	
ST-1311	11	0.75	1	72				68	66	64	61	58	54	49	38	26	
ST-1316	16	1.1	1.5	106				101	98	95	89	83	77	70	54	33	
ST-1321	21	1.5	2	142				135	132	127	122	115	108	100	79	49	
● ST-1332	32	2.2	3	208				200	194	187	177	165	152	138	104	62	
● ST-1342	42	3	4	278				261	253	242	229	214	197	179	137	78	

Dimensions and Weights				
Pump Type	Dimensions(mm)			N.W (kg)
	A	B	C	
ST-1305	236	RP : 1/4" NPT:	98	2.5
ST-1308	289		98	2.9
ST-1311	342		98	3.4
ST-1316	430		98	4.2
ST-1321	519		98	5.0
ST-1332	805		98	8.1
ST-1342	985		98	10.7

The ● means outer sleeve made by 2 pieces

Performance Curves

ST 4"

ST-18

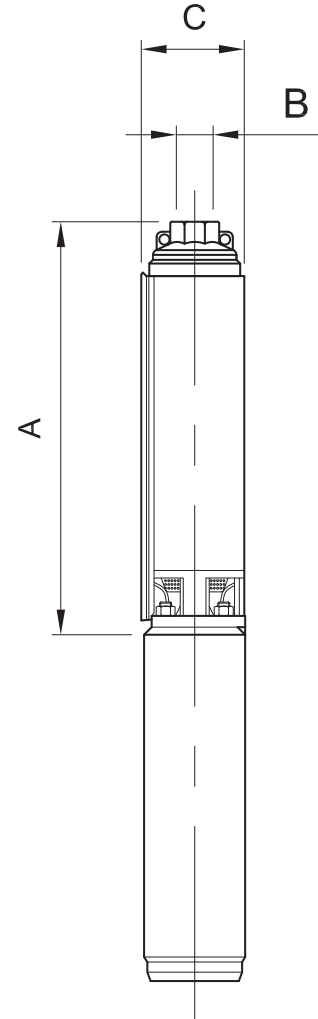
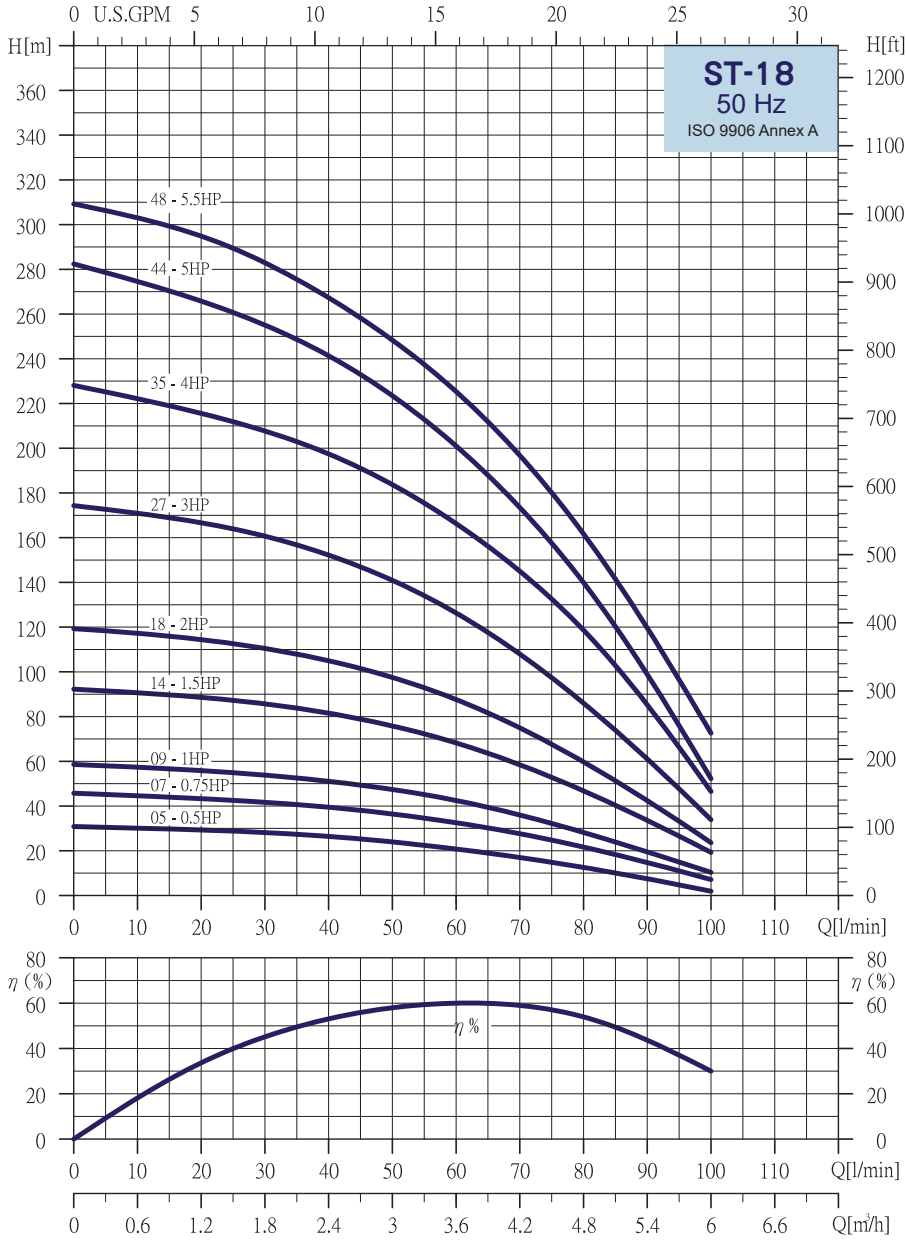

Selection Chart

PUMP TYPE	STAGES	MOTOR		Q=DELIVERY															
		KW	HP	H=TOTAL HEAD IN METERS															
				l/min 0	15	20	25	30	35	40	45	50	60	70	80	90	100		
ST-1805	5	0.37	0.5	33			29	28	27	26	25	24	21	18	13	8	3		
ST-1807	7	0.55	0.75	46			43	42	41	39	38	36	33	28	22	15	7		
ST-1809	9	0.75	1	59			55	54	52	51	49	47	43	37	28	20	10		
ST-1814	14	1.1	1.5	93			87	86	83	81	79	76	68	58	47	33	20		
ST-1818	18	1.5	2	120			113	111	108	105	102	98	88	75	60	42	25		
ST-1827	27	2.2	3	175			164	161	157	152	147	141	127	109	87	61	35		
● ST-1835	35	3	4	228			212	208	203	197	191	184	166	145	119	85	46		
● ST-1844	44	3.7	5	282			261	255	249	241	233	223	201	173	140	99	52		
● ST-1848	48	4	5.5	309			289	283	276	267	258	248	225	197	162	120	73		

Dimensions and Weights

Pump Type	Dimensions(mm)			N.W (kg)
	A	B	C	
ST-1805	257		98	2.7
ST-1807	301		98	3.0
ST-1809	344		98	3.3
ST-1814	452	RP : 1/4" NPT	98	4.1
ST-1818	538		98	4.7
ST-1827	805		98	7.2
ST-1835	995		98	8.9
ST-1844	1187		98	10.3
ST-1848	1312		98	10.9

The ● means outer sleeve made by 2 pieces

Performance Curves

ST 4"

ST-25

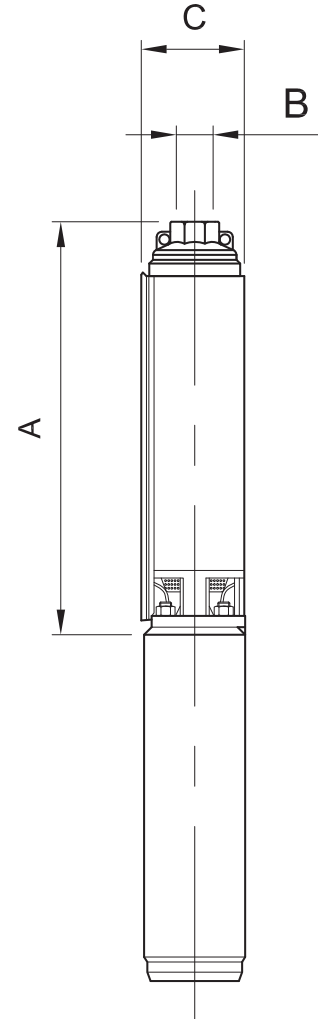
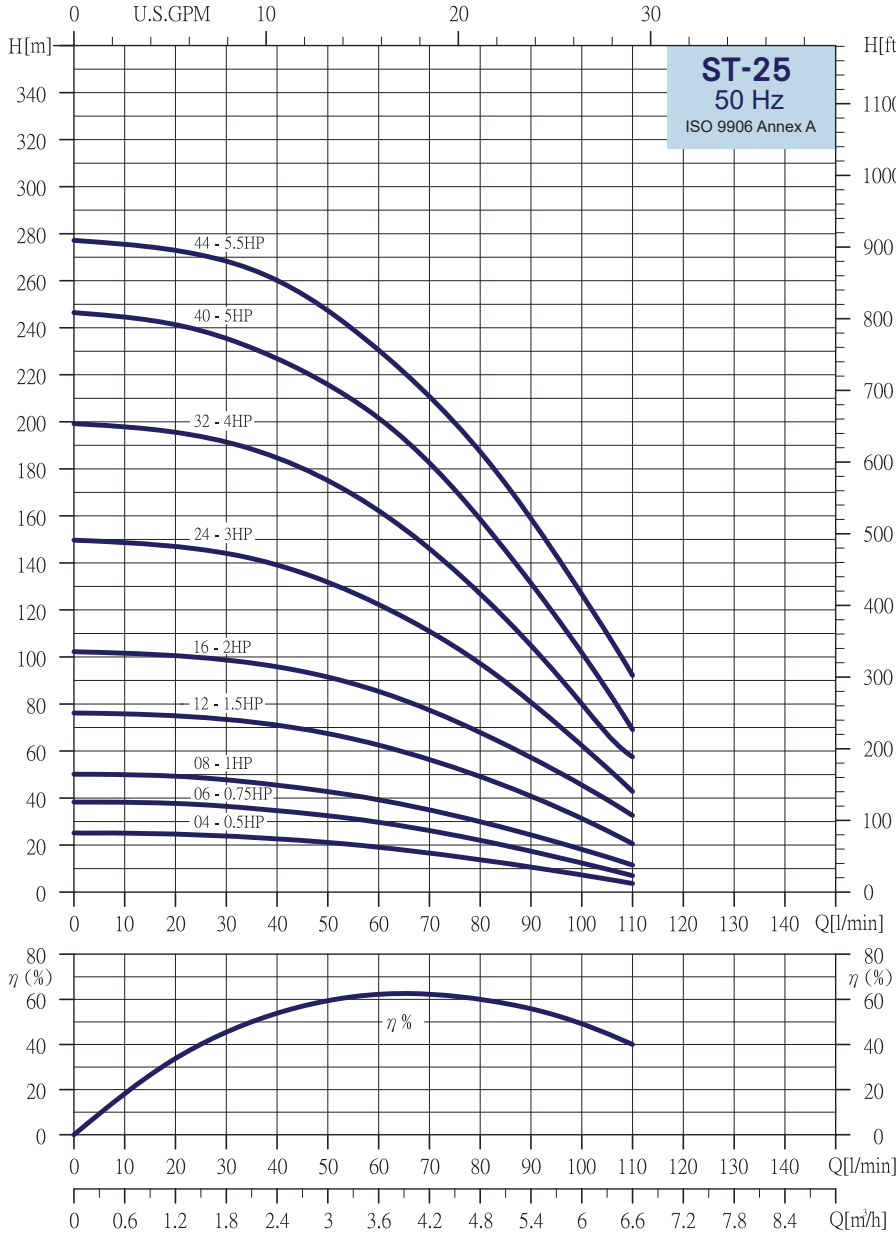

Selection Chart

PUMP TYPE	STAGES	MOTOR		Q=DELIVERY											
		KW	HP	H=TOTAL HEAD IN METERS											
				l/min 0	30	35	40	45	50	60	70	80	90	100	
ST-2504	4	0.37	0.5	26		23	22	22	21	19	17	14	11	7	
ST-2506	6	0.55	0.75	38		36	35	33	32	30	26	22	18	12	
ST-2508	8	0.75	1	51		47	46	44	43	39	35	30	24	18	
ST-2512	12	1.1	1.5	77		72	71	69	68	63	57	49	41	31	
ST-2516	16	1.5	2	102		98	96	94	92	86	77	68	57	46	
ST-2524	24	2.2	3	151		142	139	136	132	122	111	97	80	62	
● ST-2532	32	3	4	203		188	185	180	175	162	146	127	105	80	
● ST-2540	40	3.7	5	253		232	227	222	216	202	182	159	131	102	
● ST-2544	44	4	5.5	278		265	260	254	247	230	210	187	159	127	

Dimensions and Weights

Pump Type	Dimensions(mm)			N.W (kg)
	A	B	C	
ST-2504	247	RP : 1 1/2" NPT	98	2.4
ST-2506	296		98	2.9
ST-2508	345		98	3.3
ST-2512	445		98	4.1
ST-2516	542		98	5.0
ST-2524	815		98	7.6
ST-2532	1028		98	9.7
ST-2540	1220		98	11.4
ST-2544	1359		98	12.2

The ● means outer sleeve made by 2 pieces

Performance Curves

ST 4"

ST-35

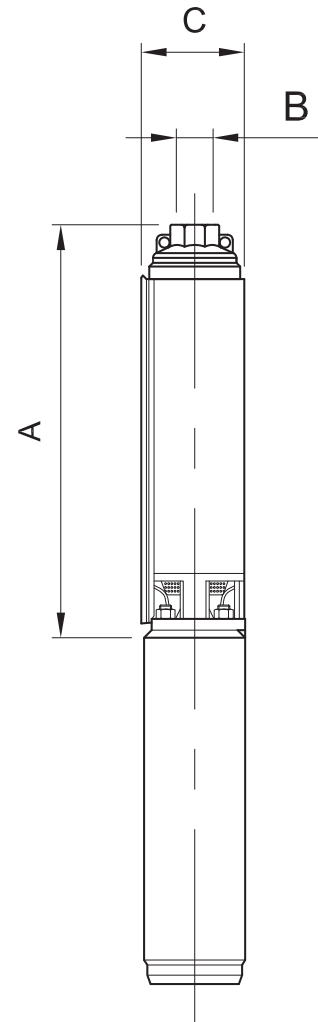
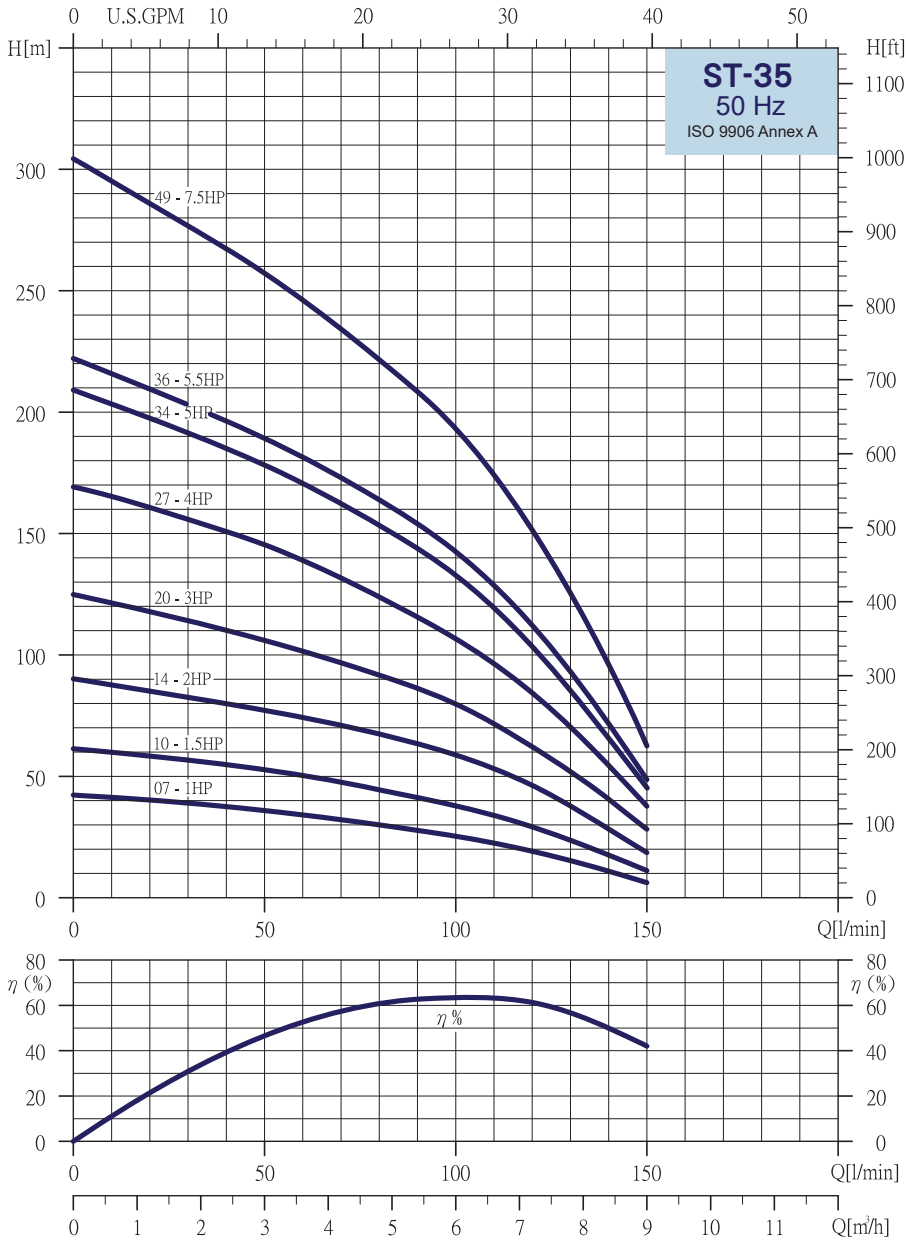

Selection Chart

PUMP TYPE	STAGES	MOTOR		Q=DELIVERY									
				H=TOTAL HEAD IN METERS									
		KW	HP	l/min 0	45	50	60	70	80	90	100	120	140
● ST-3507	7	0.75	1	42		36	34	32	30	28	25	19	11
● ST-3510	10	1.1	1.5	62		53	51	48	45	41	38	29	18
● ST-3514	14	1.5	2	90		77	74	71	68	63	59	46	28
● ST-3520	20	2.2	3	125		107	102	97	92	86	80	62	40
● ST-3527	27	3	4	169		145	139	131	123	115	107	84	55
● ST-3534	34	3.7	5	208		178	170	162	153	143	132	103	66
● ST-3536	36	4	5.5	221		190	181	173	164	154	143	112	72
● ST-3549	49	5.5	7.5	302		257	246	234	222	209	193	151	96

Dimensions and Weights

Pump Type	Dimensions(mm)			N.W (kg)
	A	B	C	
ST-3507	390	RP : 2" NPT : 2"	98	3.7
ST-3510	483		98	4.6
ST-3514	607		98	5.7
ST-3520	831		98	7.5
ST-3527	1086		99	10.6
ST-3534	1325		98	12.6
ST-3536	1384		98	13.2
ST-3549	1863		98	16.9

The ● means outer sleeve made by 2 pieces

Performance Curves

ST 4"

ST-40

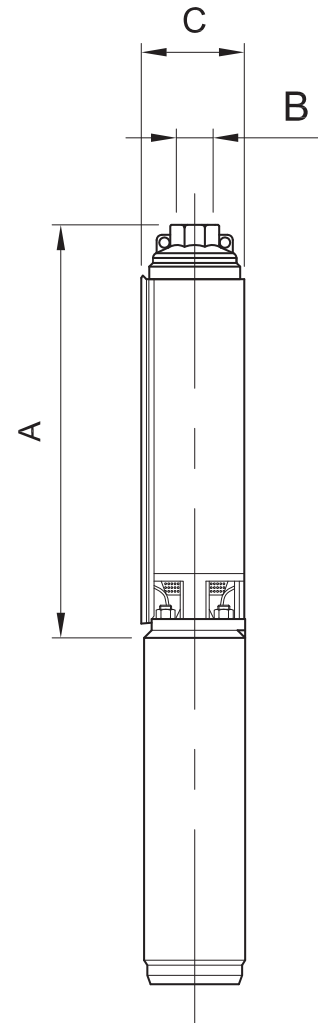
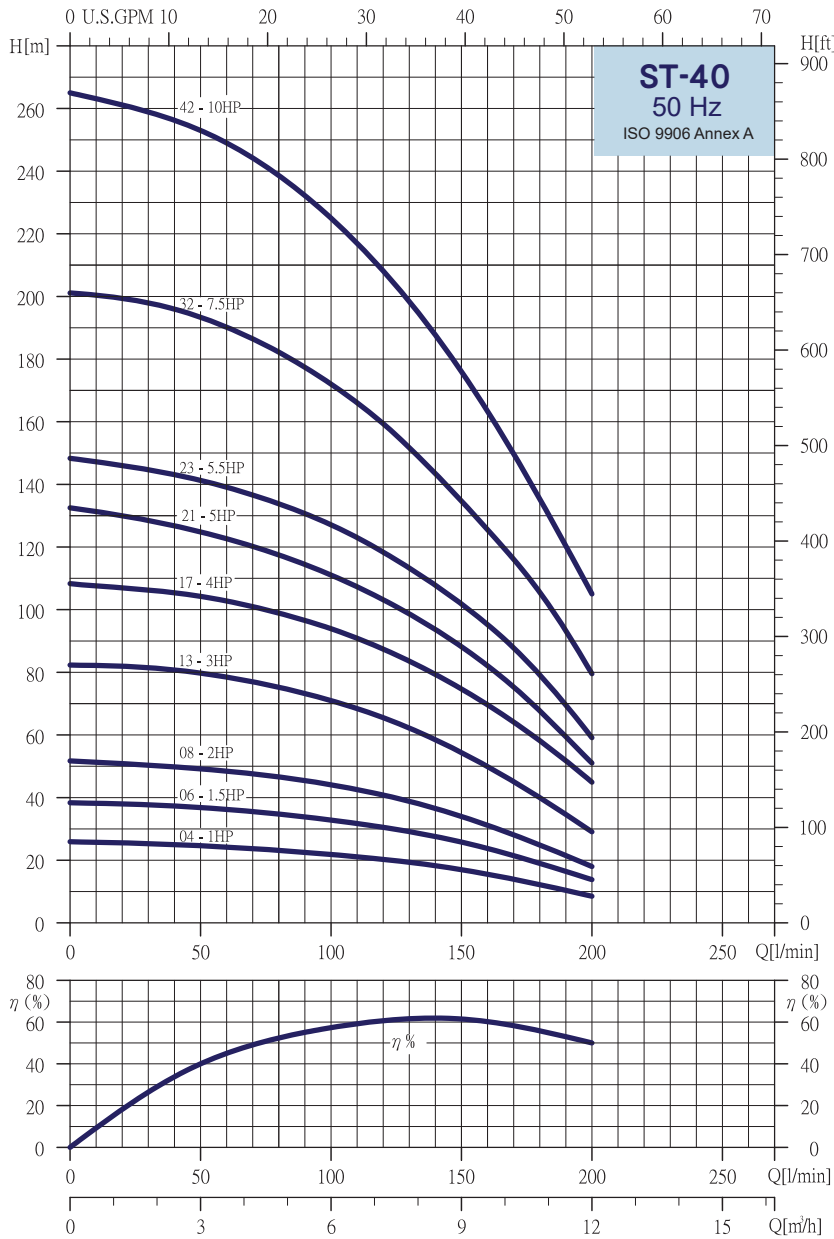

Selection Chart													
PUMP TYPE	STAGES	MOTOR		Q=DELIVERY									
				l/min	70	80	90	100	120	140	160	180	200
		KW	HP	m³/h	4.2	4.8	5.4	6	7.2	8.4	9.6	10.8	12
H=TOTAL HEAD IN METERS													
ST-4004	4	0.75	1	26		23	22	21	20	18	16	12	9
ST-4006	6	1.1	1.5	38		35	34	33	31	28	24	19	14
ST-4008	8	1.5	2	52		47	45	44	41	37	31	25	18
ST-4013	13	2.2	3	82		75	73	71	66	59	50	40	30
ST-4017	17	3	4	108		98	96	94	87	79	70	58	46
ST-4021	21	3.7	5	132		117	114	111	103	93	82	68	52
ST-4023	23	4	5.5	148		134	131	127	118	108	95	79	60
ST-4032	32	5.5	7.5	202		182	178	172	160	143	125	105	80
ST-4042	42	7.5	10	265		239	232	225	208	188	163	135	105

Dimensions and Weights				
Pump Type	Dimensions(mm)			N.W (kg)
	A	B	C	
ST-4004	301	RP : 2" NPT : 2"	98	2.8
ST-4006	356		98	3.4
ST-4008	418		98	4.0
ST-4013	573		98	5.5
ST-4017	697		98	6.6
ST-4021	859		98	7.8
ST-4023	959		98	9.4
ST-4032	1260		98	12.0
ST-4042	1650		98	15.5

The ● means outer sleeve made by 2 pieces

Performance Curves

ST 4"

ST-55

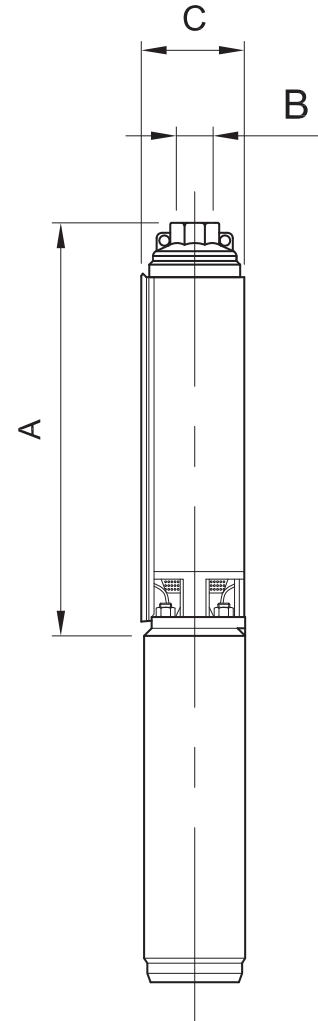
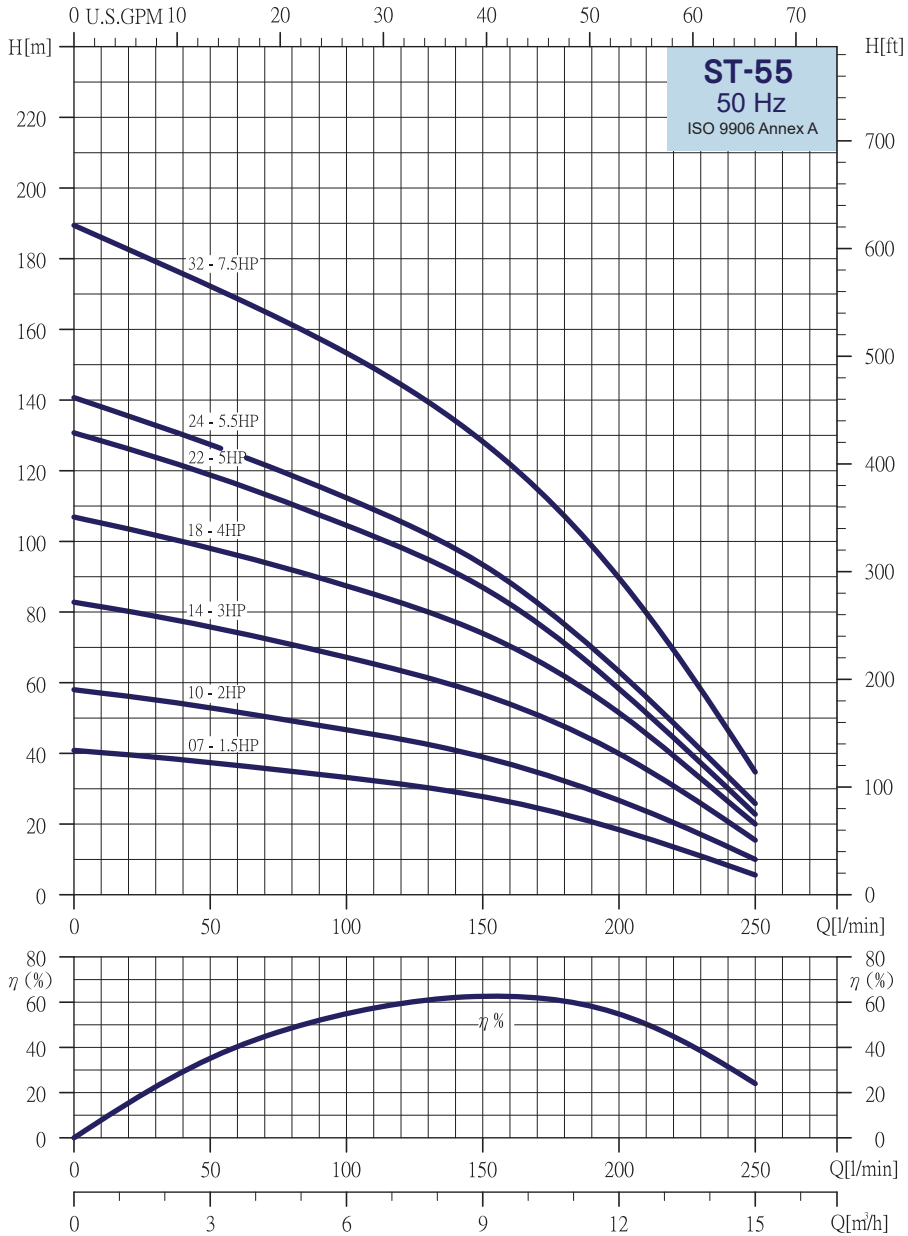

Selection Chart															
PUMP TYPE	STAGES	MOTOR		Q=DELIVERY											
				l/min	70	80	90	100	120	140	160	180	200	220	240
		KW	HP	m³/h	4.2	4.8	5.4	6	7.2	8.4	9.6	10.8	12	13.2	14.4
H=TOTAL HEAD IN METERS															
ST-5507	7	1.1	1.5	41		35	34	33	32	29	26	23	18	14	8
ST-5510	10	1.5	2	58		49	48	47	44	41	37	32	27	20	13
ST-5514	14	2.2	3	83		71	69	67	63	58	54	48	40	31	20
ST-5518	18	3	4	107		92	90	87	83	77	70	62	52	39	26
● ST-5522	22	3.7	5	131		110	107	104	98	91	82	71	58	45	30
● ST-5524	24	4	5.5	141		118	116	113	106	97	88	77	63	49	33
● ST-5532	32	5.5	7.5	189		162	157	153	144	134	122	107	90	70	47

Dimensions and Weights				
Pump Type	Dimensions(mm)			N.W (kg)
	A	B	C	
ST-5507	537	RP NPT : 2"	98	5.3
ST-5510	693		98	6.7
ST-5514	901		98	8.5
ST-5518	1185		98	11.4
ST-5522	1410		98	13.3
ST-5524	1515		98	14.2
ST-5532	1932		98	18.0

The ● means outer sleeve made by 2 pieces

Performance Curves

ST 4"

ST-60

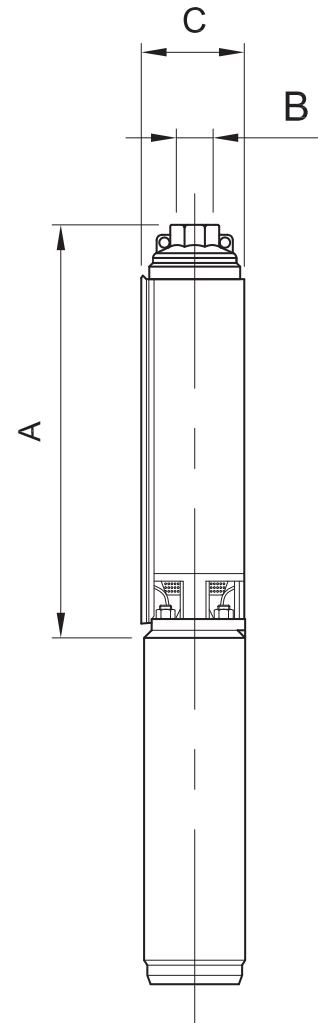
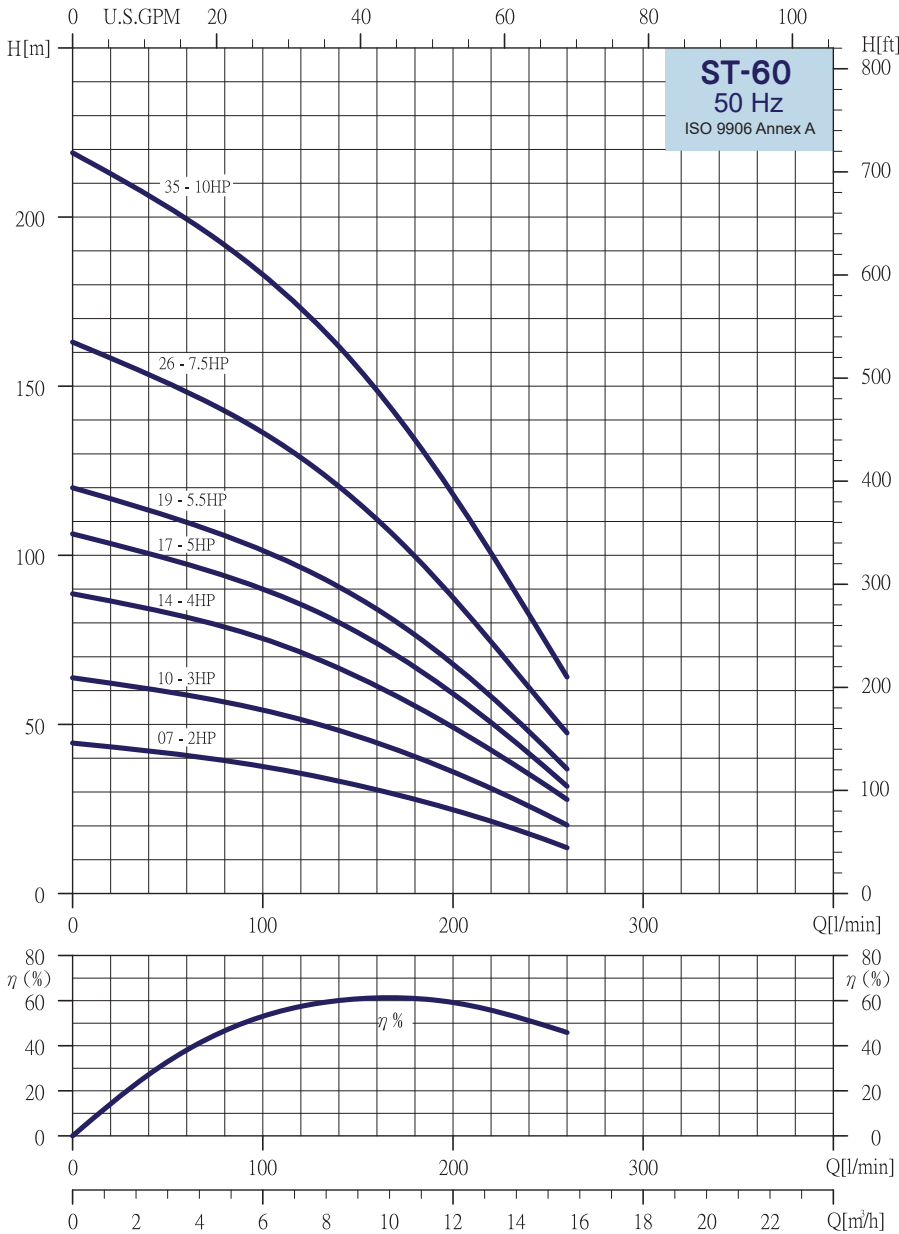

Selection Chart															
PUMP TYPE	STAGES	MOTOR		Q=DELIVERY											
				H=TOTAL HEAD IN METERS											
		KW	HP	l/min 0	90	100	120	140	160	180	200	220	240	260	
		m³/h 0	5.4	6	7.2	8.4	9.6	10.8	12	13.2	14.4	15.6			
ST-6007	7	1.5	2	45		37	36	33	31	28	25	22	18	14	
ST-6010	10	2.2	3	64		54	52	48	44	41	36	32	26	20	
ST-6014	14	3	4	89		76	72	67	62	56	49	43	35	28	
ST-6017	17	3.7	5	107		90	86	80	74	67	59	51	42	32	
ST-6019	19	4	5.5	120		102	97	91	89	76	68	58	48	37	
● ST-6026	26	5.5	7.5	163		136	129	120	111	100	87	75	61	48	
● ST-6035	35	7.5	10	219		183	173	162	149	134	118	111	82	64	

Dimensions and Weights				
Pump Type	Dimensions(mm)			N.W (kg)
	A	B	C	
ST-6007	534	RP : 2" NPT : 2"	98	5.3
ST-6010	690		98	6.7
ST-6014	989		98	8.6
ST-6017	1092		98	10.1
ST-6019	1233		98	12.0
ST-6026	1620		98	15.3
ST-6035	2165		98	19.6

The ● means outer sleeve made by 2 pieces

Performance Curves

ST 4"

ST-80

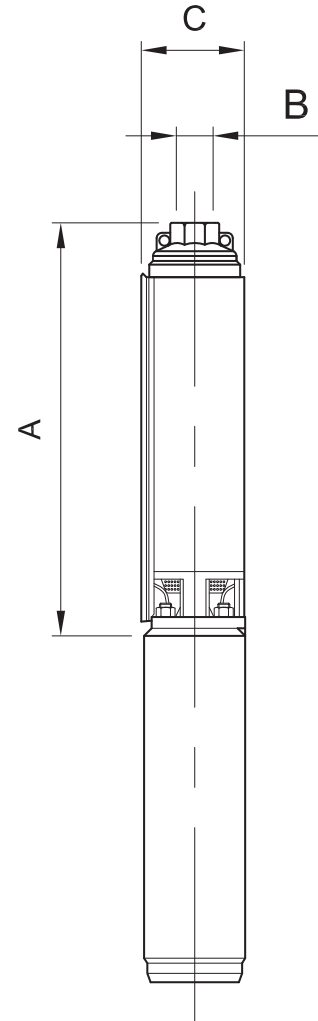
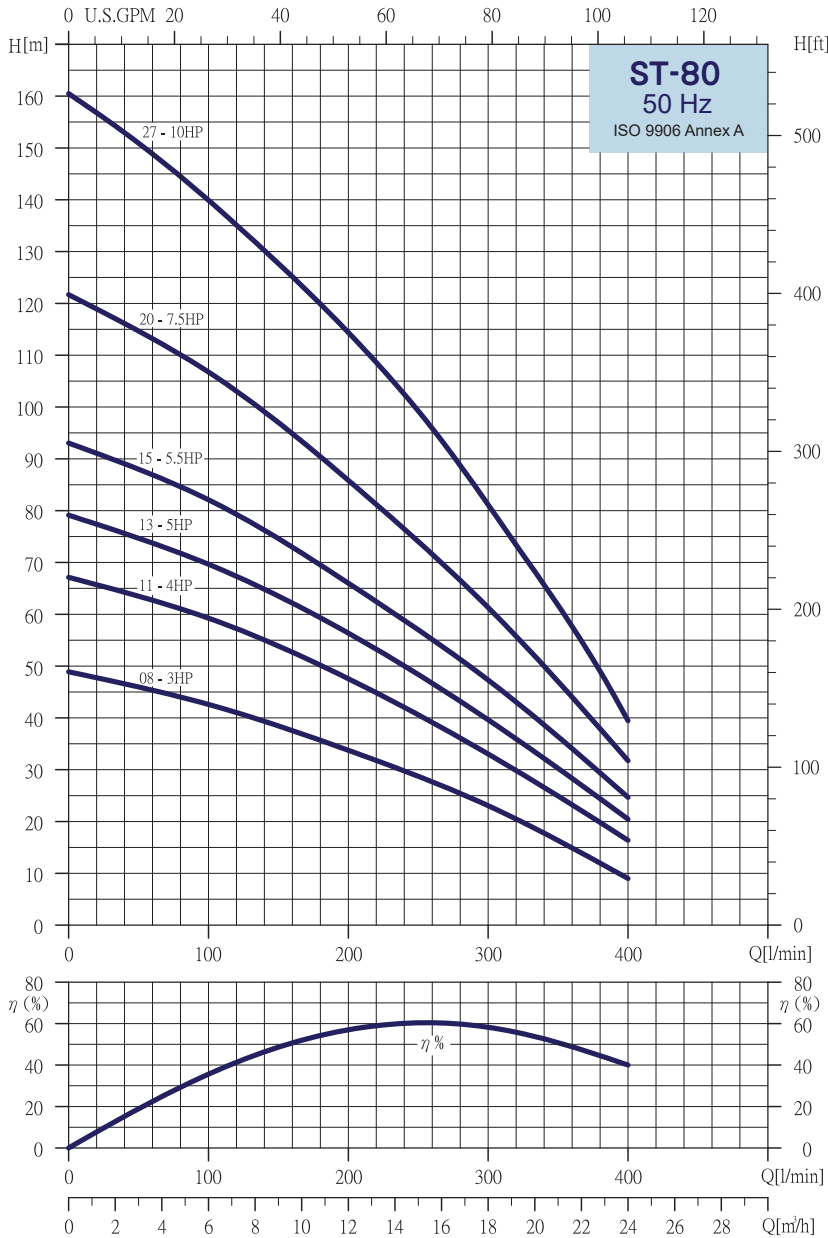

Selection Charts

PUMP TYPE	STAGES	MOTOR		Q=DELIVERY															
		KW	HP	H=TOTAL HEAD IN METERS															
				l/min 0	120	140	160	180	200	220	240	260	280	300	320	340	360	380	400
ST-8008	8	2.2	3	49		39	38	36	34	32	30	28	25	23	20	18	15	12	9
ST-8011	11	3	4	67		55	53	50	48	45	42	39	36	33	30	27	23	20	16
ST-8013	13	3.7	5	79		65	62	59	56	53	50	47	43	40	36	32	28	24	20
ST-8015	15	4	5.5	93		76	73	70	66	62	59	55	51	47	43	39	34	29	25
● ST-8020	20	5.5	7.5	122		99	95	90	86	81	76	72	67	61	56	50	44	38	32
● ST-8027	27	7.5	10	161		130	125	120	114	109	102	96	89	81	73	65	57	49	39

Dimensions and Weights

Pump Type	Dimensions (mm)			N.W (kg)
	A	B	C	
	ST-8008	676	RP : 2" NPT	98
ST-8011	880	98		8.1
ST-8013	1013	98		9.3
ST-8015	1149	98		10.5
ST-8020	1543	98		13.5
ST-8027	2020	98		18.5

The ● means outer sleeve made by 2 pieces

6" ST Submersible Pump



Model code

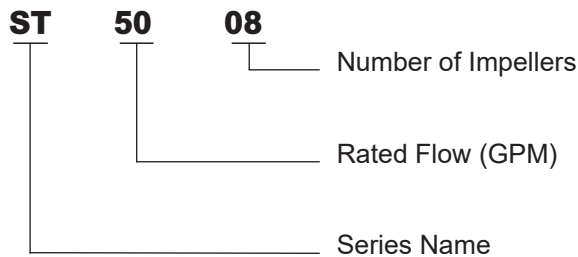

Description

The 6" submersible pumps for high pressures and flow rates, particularly equipped with a high rigidity **Silicon-Carbide(SiC) Bearing**, provide reliability and quality guaranteed.

APPLICATIONS

- Water Supply
- Irrigation
- Pressure Boosting

GENERAL SPECIFICATIONS PUMP

- Delivery: up to 24 m³/h at 2850 rpm
- Head: up to 466 m at 2850 rpm
- Maximum permissible quantity of sand: 60g/m³
- ST 50-ST75-ST135-ST180-ST220 models 3" discharge.

Discharge Head and Motor Adaptor are precision machined cast 304 stainless steel for superior strength and durability. The motor adaptor is NEMA standard.

Impellers are made with Noryl®

For a superior sand handling. Together with glass filled polycarbonate diffusers make the super strong pumps for maximum wear and abrasive resistance. The materials are FDA compliant materials.

Impeller Bowls are made from 304 stainless steel, maximizing wear from abrasion.

Shaft Coupling is made from 304 stainless steel for easy alignment to the motor shaft.

Strainer is made from stamped 304 stainless steel for rigidity.

Non-Return valve made from 304 stainless steel, fitted in the discharge to prevent any back flow of water and alleviate any water hammer to the pumps.

Pump Shaft is made from hex 304 stainless steel bar material for high corrosion resistance.

Pump body is covered by a thick 304 stainless steel casing, ensures optimum resistance to abrasion.

Performance range

ST 6"

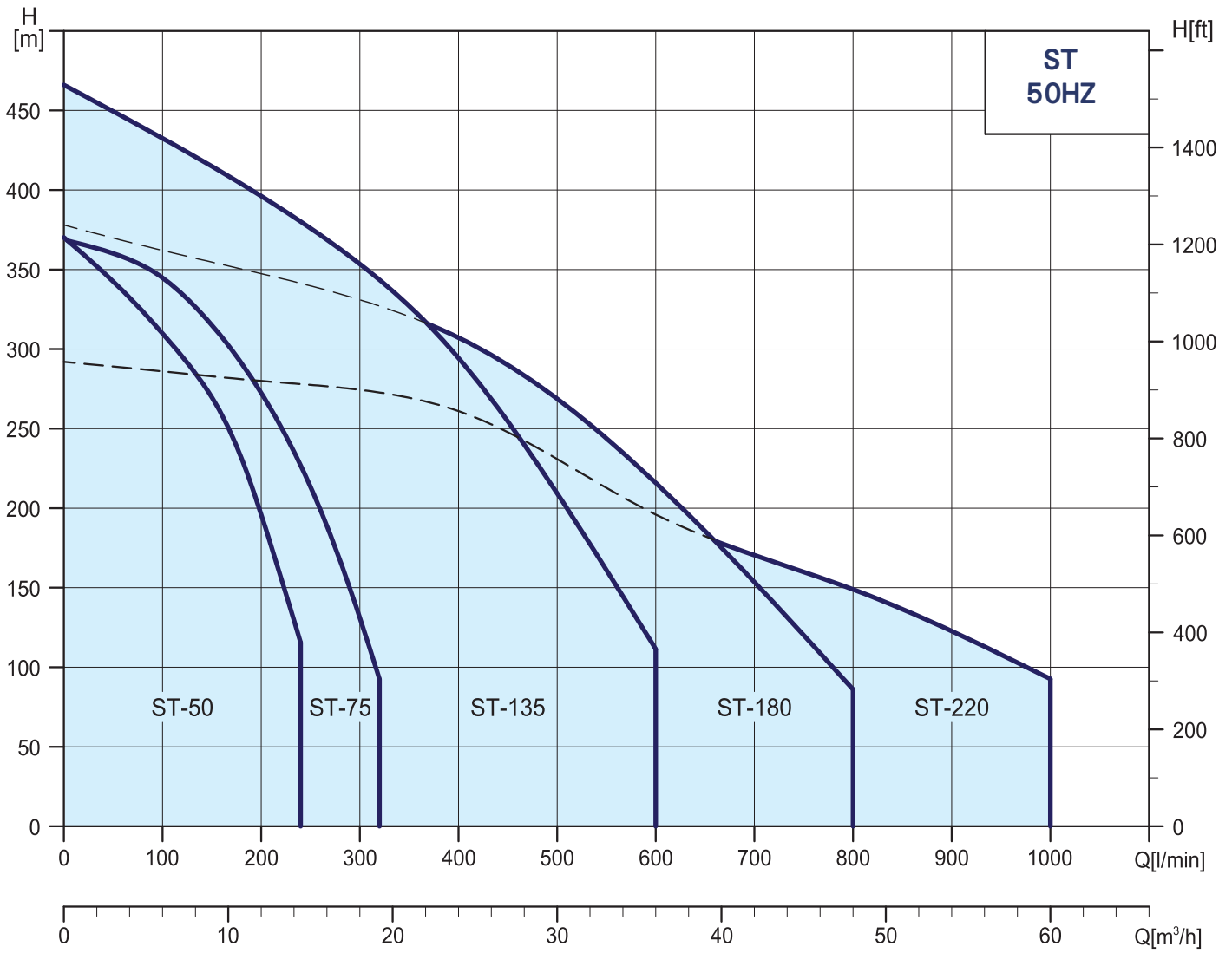

Material Specification

ST 6"

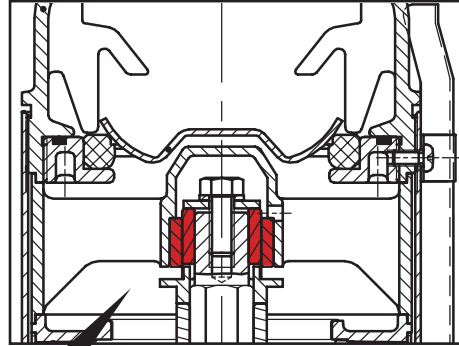
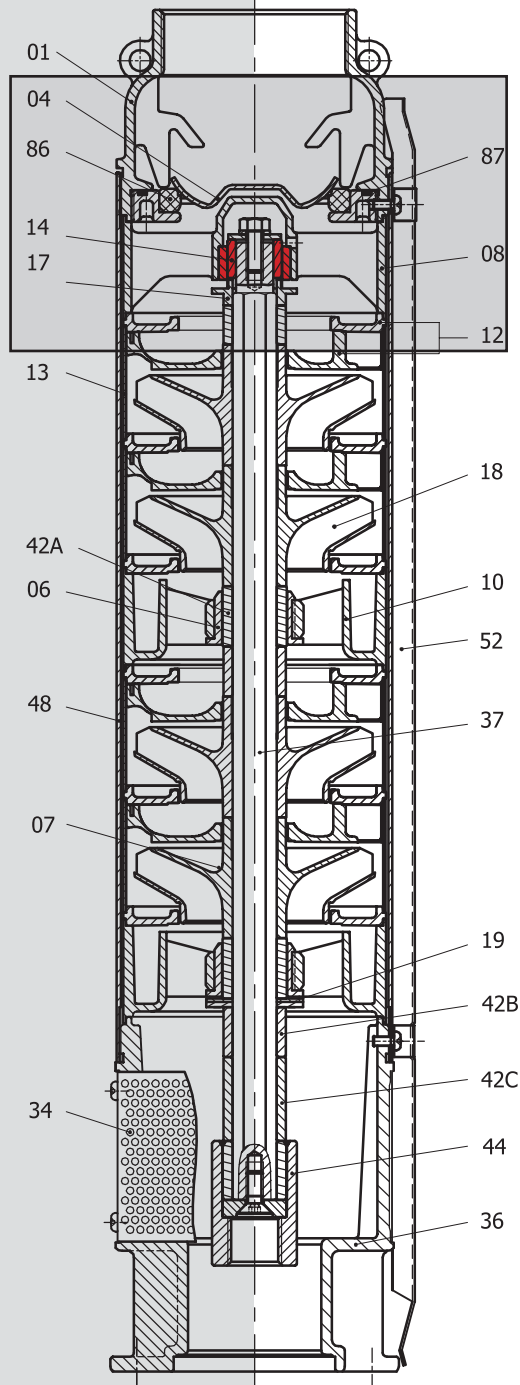

High rigidity **Silicon-Carbide(SIC) Bearing** ensure high corrosion resistance and provide long and dependable service life.

Pos.	Part Name	Material
1	Discharge	AISI 304
4	Valve cone	AISI 304
6	Bearing	POM+PTFE
7	Bearing	Bronze
8	Upper bearing spider	AISI 304 + Silicon carbide
10	Bearing Spider	Noryl
12	Diffuser	Glass Filled Polycarbonate
13	Diffuser casing	AISI 304
14	Bearing ring	Silicon carbide
17	Sleeve for baffle	AISI 304
18	Impeller	Noryl
19	Counter thrust bearing plate	Carbon fiber + PTFE
34	Strainer	AISI 304
36	Suction interconnector	AISI 304
37	Pump shaft	AISI 304
42A	Shaft sleeve	AISI 304
42B	Shaft sleeve	Noryl
42C	Shaft sleeve	Noryl
44	Coupling	AISI 304
48	Pump casing	AISI 304
52	Cable guard	AISI 304
86	Valve Seat	AISI 304 + NBR
87	O-ring	NBR

Performance Curves

ST 6"

ST-50

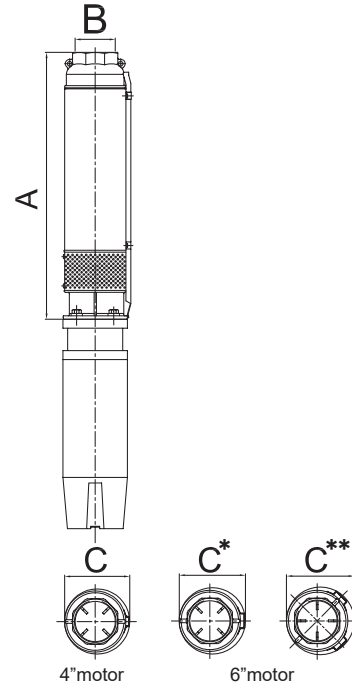
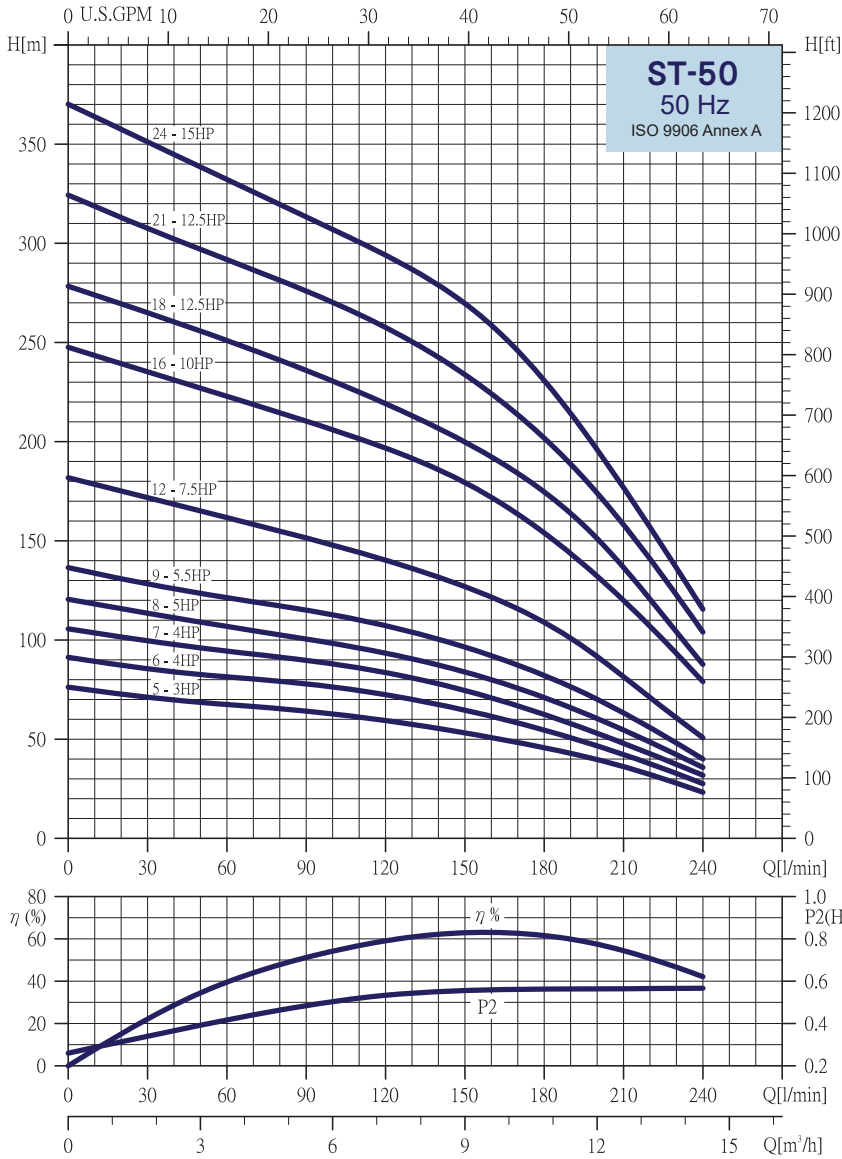

Dimensions and weights

Pump type	Motor			Dimensions (mm)					Weight (kg)
	Power		Type	A	B	C	C*	C**	Pump
	kW	HP							
ST 50-5	2.2	3	4'	539	NPT3" RP3"	138			10.3
ST 50-6	3	4	4'	577		138			11.1
ST 50-7	3	4	4'	615		138			11.8
ST 50-8	3.7	5	4'	653		138			12.5
ST 50-9	4	5.5	4'	691		138			13.1
ST 50-12	5.5	7.5	4'	805		138			15
ST 50-16	7.5	10	4'	957		138			17.7
ST 50-12	5.5	7.5	6'	819			141	144	15.9
ST 50-16	7.5	10	6'	971			141	144	18.7
ST 50-18	9.3	12.5	6'	1047			141	144	20
ST 50-21	9.3	12.5	6'	1161			141	144	21.9
ST 50-24	11	15	6'	1275			141	144	24

Selection Chart

Pump Type	Q=DELIVERY										
	l/min 0	60	80	100	120	140	160	180	200	220	240
	m³/h 0	3.6	4.8	6	7.2	8.4	9.6	10.8	12	13.2	14.4
H=TOTAL HEAD IN METERS											
ST 50-05	77	67	65	62	59	55	51	45	39	32	23
ST 50-06	92	81	79	76	72	67	61	54	46	37	27
ST 50-07	106	94	91	88	84	79	71	62	53	42	32
ST 50-08	121	107	102	98	93	87	80	71	60	48	35
ST 50-09	137	121	117	112	107	100	92	82	70	56	40
ST 50-12	182	161	155	148	140	131	121	109	91	71	50
ST 50-16	248	223	214	206	196	186	172	154	132	107	79
ST 50-18	279	251	241	230	219	206	192	174	151	120	87
ST 50-21	325	292	281	270	257	242	224	201	174	141	104
ST 50-24	371	332	319	307	294	279	258	231	196	156	115

Performance Curves

ST 6"

ST-75

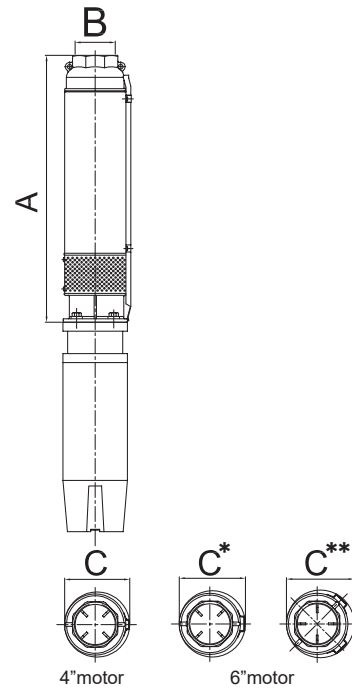
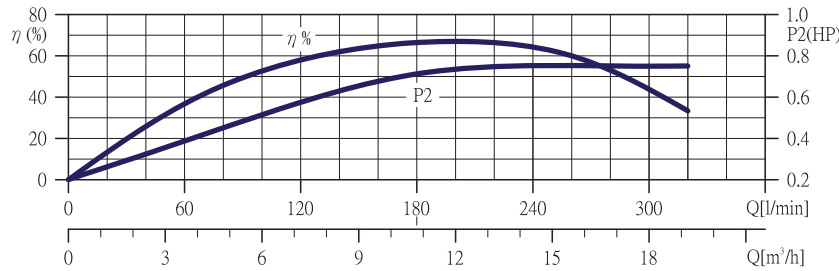
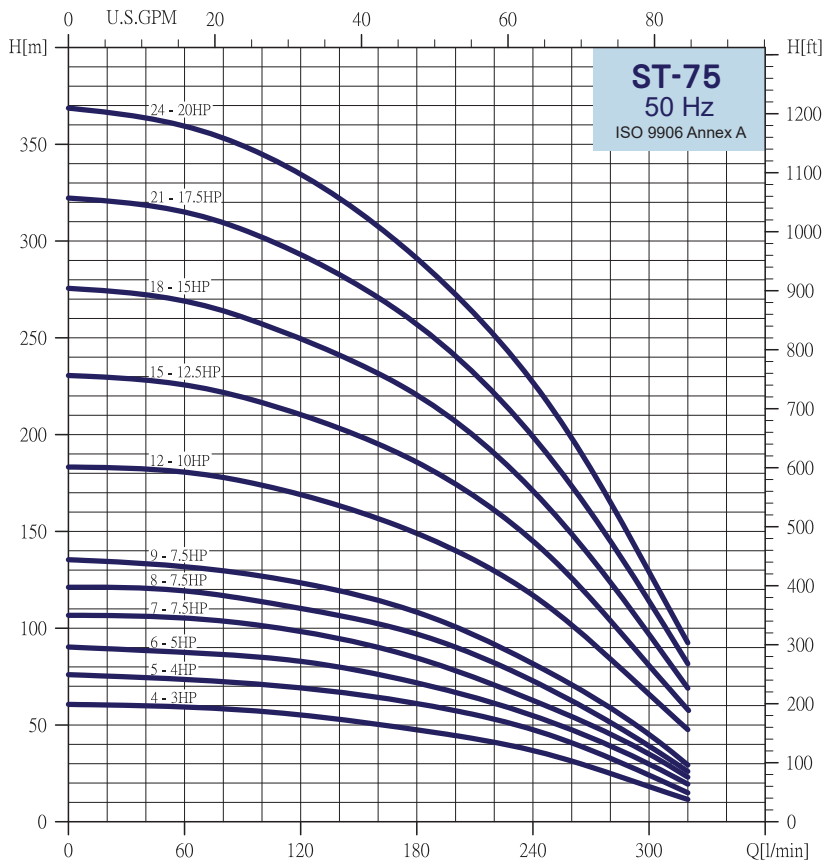

Dimensions and weights

Pump type	Motor			Dimensions(mm)					Weight(kg)	
	Power		Type	A	B	C	C*	C**		
	kW	HP								
ST 75-4	2.2	3	4"	501	NPT3"	138			9.6	
ST 75-5	3	4	4"	539		138			10.3	
ST 75-6	3.7	5	4"	577		138			11	
ST 75-7	5.5	7.5	4"	615		138			11.7	
ST 75-8	5.5	7.5	4"	653		138			12.5	
ST 75-9	5.5	7.5	4"	691		138			13.1	
ST 75-12	7.5	10	4"	805		138			15	
ST 75-7	5.5	7.5	6"	629		RP3"		141	144	12.5
ST 75-8	5.5	7.5	6"	667				141	144	13.2
ST 75-9	5.5	7.5	6"	705				141	144	13.9
ST 75-12	7.5	10	6"	819				141	144	15.8
ST 75-15	9.3	12.5	6"	933				141	144	17.8
ST 75-18	11	15	6"	1047				141	144	19.9
ST 75-21	13	17.5	6"	1161				141	144	21.8
ST 75-24	15	20	6"	1275				141	144	23.8

Selection Chart

Pump Type	Q=DELIVERY											
	l/min 0	120	140	160	180	200	220	240	260	280	300	320
	m³/h 0	7.2	8.4	9.6	10.8	12	13.2	14.4	15.6	16.8	18	19.2
H=TOTAL HEAD IN METERS												
ST 75-04	61	55	53	50	47	44	41	37	31	25	18	11
ST 75-05	77	69	67	64	61	57	53	47	40	33	24	15
ST 75-06	91	82	80	76	71	67	61	55	47	39	29	19
ST 75-07	107	98	94	90	84	78	70	62	54	45	35	23
ST 75-08	122	110	106	102	97	90	82	73	62	51	39	26
ST 75-09	136	123	119	114	108	101	91	81	71	59	45	29
ST 75-12	184	169	163	156	149	140	129	117	101	84	66	47
ST 75-15	231	210	203	195	185	174	161	145	126	104	80	57
ST 75-18	276	249	241	231	220	206	190	171	148	123	97	69
ST 75-21	323	293	282	271	257	240	221	199	173	145	114	81
ST 75-24	369	334	322	307	291	272	251	227	198	165	129	92

Performance Curves

ST 6"

ST-135

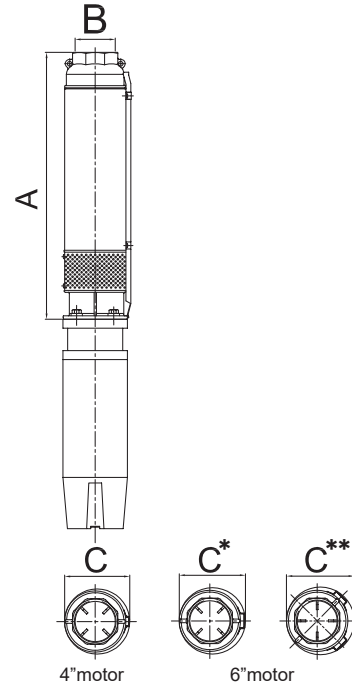
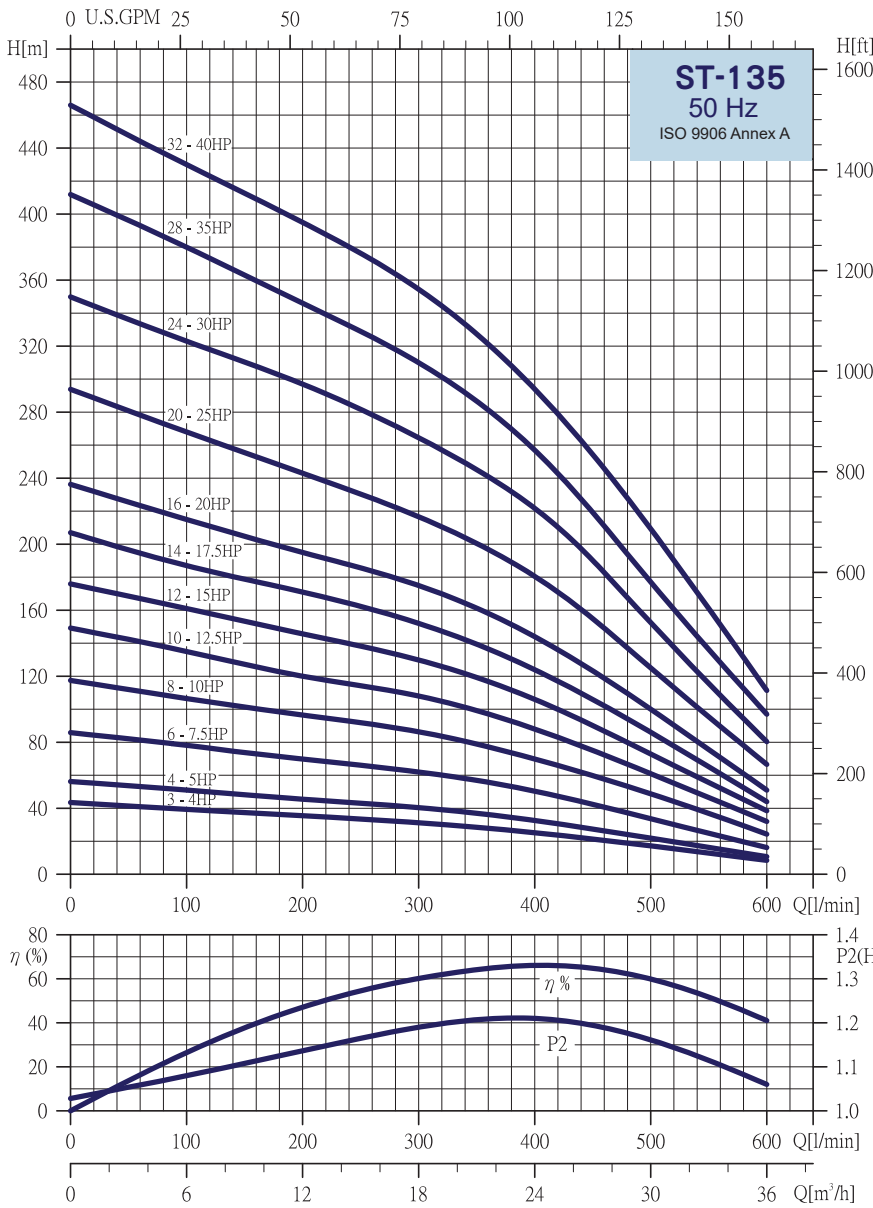

Dimensions and weights

Pump type	Motor			Dimensions (mm)					Weight (kg)
	Power kW	HP	Type	A	B	C	C*	C**	
ST 135-3	3	4	4"	520	NPT3" RP3"	138			9.9
ST 135-4	3.7	5	4"	577		138			10.8
ST 135-6	5.5	7.5	4"	691		138			12.6
ST 135-8	7.5	10	4"	805		138			14.3
ST 135-6	5.5	7.5	6"	705			141	144	13.5
ST 135-8	7.5	10	6"	819			141	144	15.2
ST 135-10	9.3	12.5	6"	933			141	144	17
ST 135-12	11	15	6"	1047			141	144	18.9
ST 135-14	13	17.5	6"	1161			141	144	20.7
ST 135-16	15	20	6"	1275			141	144	22.6
ST 135-20	18.5	25	6"	1555			141	144	27
ST 135-24	22	30	6"	1783			141	144	30.7
ST 135-28	26	35	6"	2063			141	144	35.1
ST 135-32	30	40	6"	2291			141	144	38.9

Selection Chart

Pump Type	Q=DELIVERY											
	l/min 0	200	240	280	320	360	400	440	480	520	560	600
	m³/h 0	12	14.4	16.8	19.2	21.6	24	26.4	28.8	31.2	33.6	36
H=TOTAL HEAD IN METERS												
ST 135-03	44	36	34	32	30	28	25	22	19	15	12	8
ST 135-04	57	45	43	41	39	36	32	28	24	19	15	10
ST 135-06	86	69	66	63	60	55	50	44	37	30	23	16
ST 135-08	118	96	92	88	83	77	70	62	53	44	34	24
ST 135-10	150	120	115	110	105	97	88	77	66	55	43	32
ST 135-12	176	145	139	133	126	116	106	93	80	66	52	38
ST 135-14	207	171	164	156	147	136	124	109	94	77	61	44
ST 135-16	237	195	187	179	170	158	144	127	109	90	70	51
ST 135-20	294	243	233	222	210	197	180	160	137	113	89	66
ST 135-24	350	297	285	271	257	241	221	197	167	137	108	80
ST 135-28	412	346	332	318	301	281	257	227	194	160	128	97
ST 135-32	466	395	380	363	344	321	294	262	228	190	151	111

Performance Curves

ST 6"

ST-180

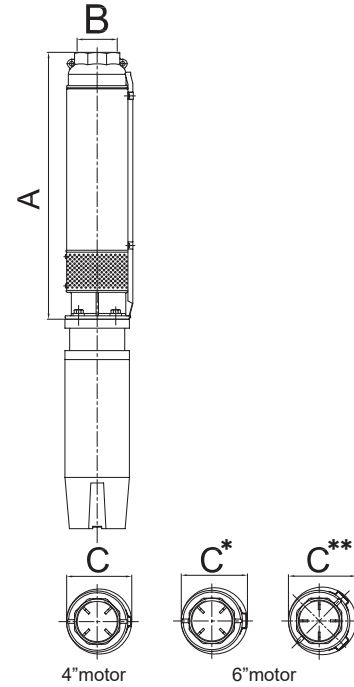
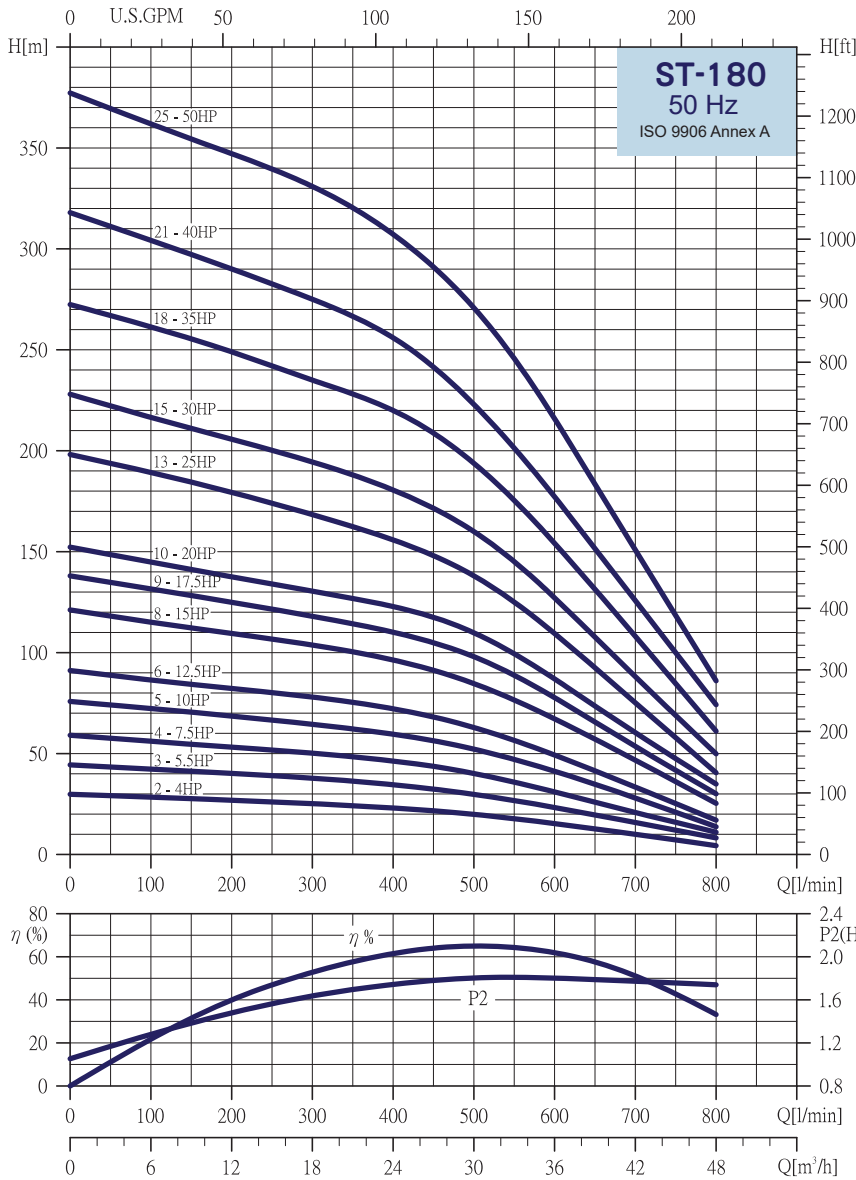

Dimensions and weights

Pump type	Motor			Dimensions (mm)					Weight (kg)
	Power		Type	A	B	C	C*	C**	
	kW	HP							
ST 180-2	3	4	4"	469		138			8.9
ST 180-3	4	5.5	4"	529		138			9.9
ST 180-4	5.5	7.5	4"	589		138			10.7
ST 180-5	7.5	10	4"	649		138			11.8
ST 180-6	9.3	12.5	6"	723			141	144	11.6
ST 180-8	11	15	6"	843			141	144	15.5
ST 180-9	13	17.5	6"	903			141	144	16.5
ST 180-10	15	20	6"	963			141	144	17.4
ST 180-13	18.5	25	6"	1143			141	144	20.3
ST 180-15	22	30	6"	1263			141	144	22.2
ST 180-18	26	35	6"	1495			141	144	25.9
ST 180-21	30	40	6"	1675			141	144	28.6
ST 180-25	37	50	6"	1915			141	144	32.5

Selection Chart

Pump Type	Q=DELIVERY											
	l/min 0	300	350	400	450	500	550	600	650	700	750	800
	m³/h 0	18	21	24	27	30	33	36	39	42	45	48
H=TOTAL HEAD IN METERS												
ST 180-02	30	25	24	23	21	20	17	15	12	10	7	4
ST 180-03	45	38	36	34	32	29	26	23	19	16	12	8
ST 180-04	59	50	48	46	43	40	36	31	26	21	16	11
ST 180-05	76	64	62	59	56	52	47	41	35	28	21	13
ST 180-06	92	78	75	72	68	63	56	49	41	33	25	17
ST 180-08	122	103	100	96	91	84	76	67	57	46	36	25
ST 180-09	138	118	114	110	105	98	88	77	65	53	41	30
ST 180-10	153	130	127	123	117	110	99	87	73	60	47	35
ST 180-13	199	168	162	156	148	138	125	109	92	75	58	40
ST 180-15	228	194	188	180	171	160	145	127	107	88	69	50
ST 180-18	273	235	228	220	208	194	175	154	131	108	84	61
ST 180-21	318	275	266	256	241	223	201	177	151	125	100	74
ST 180-25	378	331	320	307	291	271	245	216	183	151	118	86

Performance Curves

ST 6"

ST-220

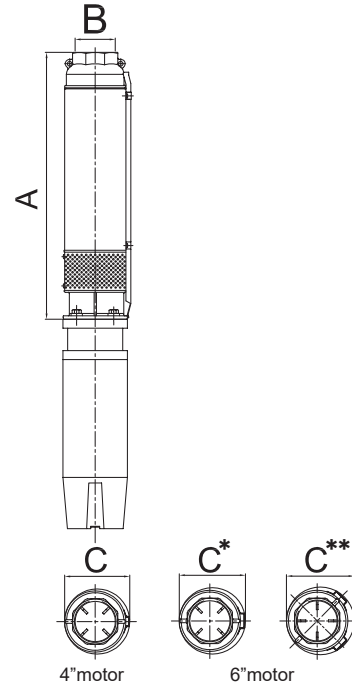
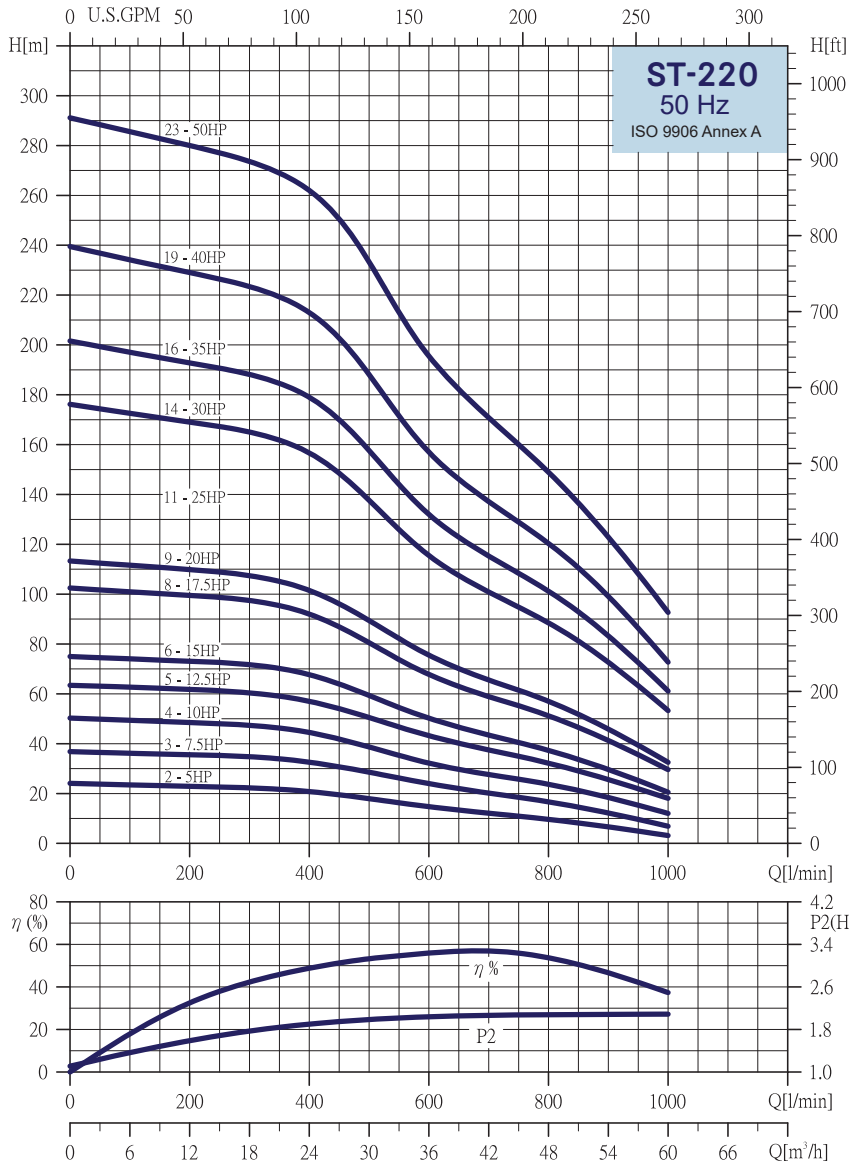

Dimensions and weights

Pump type	Motor			Dimensions(mm)					Weight(kg)
	Power	HP	Type	A	B	C	C**		
							C*	C**	
ST 220-2	3.7	5	4"	469	NPT3"	138			8.9
ST 220-3	5.5	7.5	4"	529		138			9.9
ST 220-4	7.5	10	4"	589		138			10.8
ST 220-3	5.5	7.5	6"	543			141	144	10.7
ST 220-4	7.5	10	6"	603			141	144	11.7
ST 220-5	9.3	12.5	6"	663			141	144	12.6
ST 220-6	11	15	6"	723		RP3"	141	144	13.6
ST 220-8	13	17.5	6"	843			141	144	15.5
ST 220-9	15	20	6"	903			141	144	16.5
ST 220-11	18.5	25	6"	1023			141	144	18.5
ST 220-14	22	30	6"	1203			141	144	21.5
ST 220-16	26	35	6"	1323			141	144	23.6
ST 220-19	30	40	6"	1555			141	144	27.6
ST 220-23	37	50	6"	1795			141	144	31.3

Selection Chart

Pump Type	Q=DELIVERY											
	l/min 0	400	450	500	550	600	650	700	750	800	900	1000
	m ³ /h 0	24	27	30	33	36	39	42	45	48	54	60
H=TOTAL HEAD IN METERS												
ST 220-02	25	21	19	18	16	14	13	13	11	9	6	3
ST 220-03	37	32	30	28	26	24	22	21	18	16	12	7
ST 220-04	51	44	42	38	35	32	29	28	25	23	18	12
ST 220-05	64	57	54	50	46	43	40	38	35	32	25	18
ST 220-06	75	67	64	59	54	50	46	44	40	37	29	20
ST 220-08	103	92	87	80	74	67	63	59	55	51	41	29
ST 220-09	114	101	96	89	82	75	70	66	61	57	46	32
ST 220-11	139	124	118	109	100	92	85	81	75	70	56	41
ST 220-14	177	156	148	137	126	115	107	101	94	88	72	53
ST 220-16	202	179	170	157	144	132	123	116	108	101	83	61
ST 220-19	240	213	202	188	171	157	146	138	129	120	99	72
ST 220-23	292	262	250	233	213	195	182	171	160	149	123	92



www.sistema.it